

exhaust gas heat exchangers

EXHAUST GAS HEAT EXCHANGERS



BOWMAN[®]
100 YEARS OF HEAT TRANSFER TECHNOLOGY

mdt

authorised regional warehouse
and distributor of E.J. Bowman

www.mdtco.com

Turning waste heat

Bowman Exhaust Gas Heat Exchangers

Recovering valuable heat energy from the exhaust stream of engine powered Combined Heat & Power (CHP) systems

An exhaust gas heat exchanger (EGHE) is an extremely effective way of recovering valuable waste heat energy from an engine powered generating set.

By recovering waste heat from the engine's exhaust stream, the overall efficiency of a gen-set can be increased from approximately 30% (power only), to around 60% (with EGHE Only) and 80% + when heat is recovered from the engines cooling system, induction air, plus lubrication and fuel systems. See page 10 for more information.

As the UK's leading manufacturer of exhaust gas heat exchangers, Bowman offer a comprehensive range of highly efficient units, suitable for applications up to 1MW, for engines using Biogas, Diesel, Natural Gas and Hydrogen.

Bowman EGHEs are designed for a wide range of commercial or industrial applications, including district heating and hot water, space heating, thermal oil heating, generating electricity through ORC or Stirling engine technology, or running a chiller for cooling.

Extensively proven in some of the most challenging installations on earth, Bowman exhaust gas heat exchangers are high quality units that combine high levels of heat recovery, with long life durability.



Shell and tube design

All Bowman units are based on the company's renowned shell and tube heat exchanger design, which combines excellent heat transfer performance with ease of installation and simple maintenance.

All stainless steel construction

The fully welded, all stainless steel construction of Bowman's EGHEs, ensures maximum reliability and durability of the unit when handling extreme exhaust gas temperatures.

Automated tube welding

Automated tube end welding and 100% inspection, ensures the highest quality and structural integrity of the tube core for maximum reliability.

Installation options

Bowman offer three ranges of exhaust gas heat exchangers: (i) without end covers, for direct connection into customer's pipework, (ii) straight end covers and (iii) 90° (right angle) end covers.

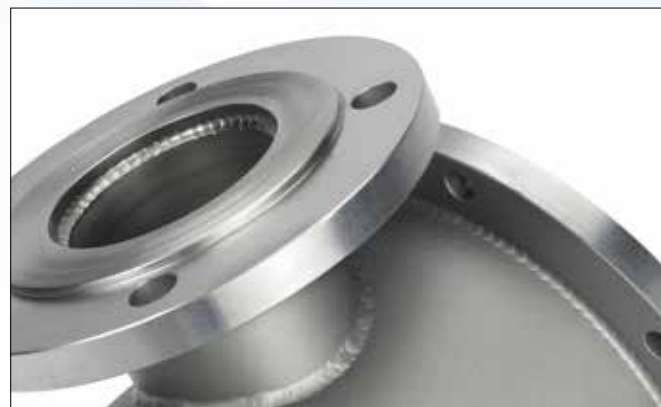

into vital energy



Bowman exhaust gas units are installed in the CHP system within the British Arctic Survey's Halley VI research station



In Canada, Bowman exhaust gas units within a Cogen system, provide heat for a remote 'off-grid' community



An 'eco village' in Finland relies on Bowman units to recover waste heat energy for heating and hot water

Easy Product Selection

To make product selection simple and accurate, we have developed a computer aided selection programme. See page 4 for details.

Right angle end covers

Available across the range, these end covers enable more compact packaging and often reduce pipework requirements. They also enable the tubes to be cleaned without disturbing the pipework.

PN6 flanges

All end cover and shell side flanges are PN6 to BS EN1092 for ease of installation.

Pressure relief valve

Bowman EGHEs are fitted with a pressure relief valve as a safety feature. Should pressure exceed 4 bar on the water side, it automatically activates to prevent excess pressure build up.

Comprehensive specification

In addition to drain plugs and bosses for vents and temperature sensors, all Bowman EGHEs are supplied with mounting brackets as standard, for ease of installation.

Exhaust Gas Heat Exchangers

Product Range

The figures given below are typical examples of the performance of Bowman exhaust gas heat exchangers. They are intended as a general guide and are based on a natural gas engine with an exhaust gas temperature of 600°C and a water temperature of 80°C.

However, simply by providing the following information, we can recommend the correct heat exchanger for your application using our computer aided selection programme;

- 1: Exhaust gas mass flow rate in kg/min
- 2: Maximum allowable pressure drop in kPa
- 3: Exhaust gas inlet and desired outlet temperature in °C
- 4: Cooling water temperature in °C
- 5: Cooling water flow rate in l/min
- 6: Source of cooling water

Note: water temperature must not exceed 110°C at 4 bar and gas inlet should be below 0.5 bar and 700°C.



Type	Typical Engine Power	Exhaust Gas Flow	Exhaust Gas Outlet Temp	Heat Recovery	Exhaust Gas Pressure Drop
	kW	kg / min	°C	kW	kPa
2-25-3737-4	16	1.2	210	9.5	1.6
2-32-3737-5	16	1.2	170	11.5	1.8
3-32-3738-5	32	2.4	198	19	1.2
3-40-3738-6	32	2.4	163	21	1.3
3-60-3738-8	32	2.4	116	23	1.6
4-32-3739-5	60	4.5	199	36	1.0
4-40-3739-6	60	4.5	164	39	1.2
4-60-3739-8	60	4.5	116	43	1.4
5-32-3740-5	90	6.7	195	55	1.0
5-40-3740-6	90	6.7	161	59	1.1
5-60-3740-8	90	6.7	115	65	1.4
6-32-3741-5	140	10.5	197	85	1.0
6-40-3741-6	140	10.5	163	92	1.2
6-60-3741-8	140	10.5	117	101	1.4
8-32-3742-5	250	18.7	199	151	1.0
8-40-3742-6	250	18.7	164	163	1.2
8-60-3742-8	250	18.7	117	180	1.4
10-32-3743-5	400	30.0	200	241	1.1
10-40-3743-6	400	30.0	164	262	1.2
10-60-3743-8	400	30.0	116	289	1.4
12-32-3744-5	600	45.0	199	362	1.1
12-40-3744-6	600	45.0	164	392	1.2
12-60-3744-8	600	45.0	117	432	1.5
15-32-5745-5	950	70.0	200	563	1.0
15-40-5745-6	950	70.0	165	610	1.1
15-60-5745-8	950	70.0	116	673	1.4

For larger sizes contact our sales department.

100kPa = 1 bar

European Pressure Equipment Directive

This range of products fall within Article 3 Paragraph 3. (Sound Engineering Practice) and do not require CE marking

Exhaust Gas Heat Exchangers

Selection Guidance

- 1: From the exhaust gas heat exchanger range shown on page 4, first identify the engine size and then select the unit that will cool the exhaust gas to the desired outlet temperature and recover the required amount of heat.
- 2: As a general guide, the heat exchanger length determines the gas temperature reduction and the diameter determines the pressure drop.
- 3: For diesel powered engines, the exhaust gas temperature should not fall below 180°C, as below this temperature, soot deposits can build up inside the heat exchanger, reducing efficiency and necessitating cleaning to restore performance.
- 4: At temperatures below 180°C, condensation will occur, which can cause problems for the heat exchanger as well as any materials downstream of the unit.
- 5: Always specify the gas mass flow, preferably in kg/min. Volume flows should be avoided because without also stating the pressure and temperature at which they are measured, they are meaningless. Temperatures can be given in Celsius, but if any calculations are to be made involving the universal gas laws, absolute temperatures in Kelvin must be used. To convert from Celsius to Kelvin, add 273.
- 6: It should be noted that adding an exhaust gas heat exchanger to an existing system will reduce the gas volume and velocity after the heat exchanger, thus reducing the back pressure through the silencer and the rest of the system. Typically, this reduction will be more than the back pressure through the heat exchanger, meaning that the addition of a heat exchanger to an existing system will often reduce the total system back pressure.
- 7: The target gas pressure drop through the heat exchanger should be about half the total back pressure permitted by the engine manufacturer. Consideration should also be given to the silencer. When specifying, ensure the supplier has the actual gas inlet temperature and the mass flow in kg/min, in addition to noise reduction requirements. Please note that for any gas flow through a particular silencer, back pressure will be proportional to the absolute gas temperature in Kelvin.

Exhaust Gas Heat Exchangers

Application Choice

Bowman exhaust gas heat exchangers are available in a choice of three ranges to suit the requirements of the application:

Without end covers

This option enables the unit to be connected directly into the installation pipework.

Straight end covers

With PN6 flange connections on the end covers these units provide installation flexibility for using on a wide range of applications.

Right angle end covers

Designed to provide a more compact installation which can often reduce pipework, these end covers can be rotated to suit exhaust gas pipework.



Without end covers

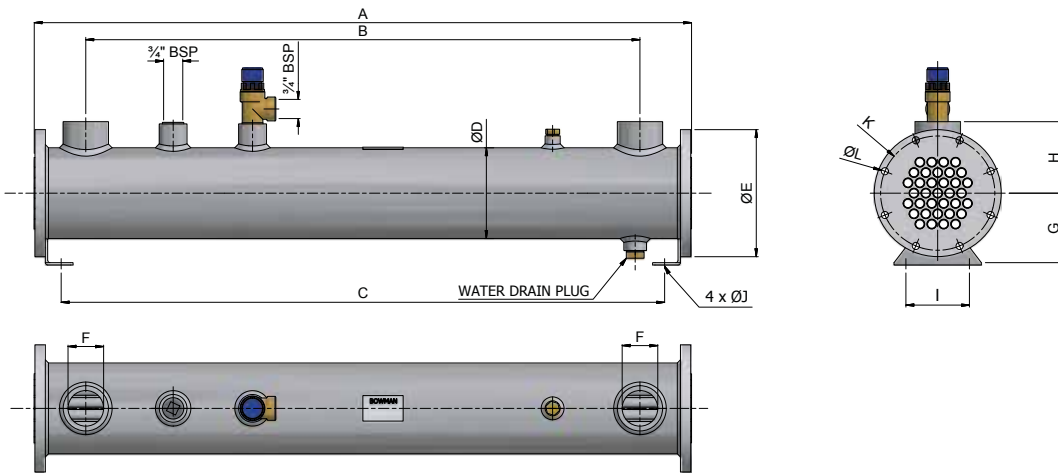

Type	A mm	B mm	C mm	D mm	E mm	F BSP	G mm	H mm	I mm	J mm	K	L	kg
2-25-4737-4	648	550	588	60.3	106	3/4"	65	55	60	9	90 PCD	4 x 9	7
2-32-4737-5	826	728	766	60.3	106	3/4"	65	55	60	9	90 PCD	4 x 9	8
3-32-4738-5	826	718	760	88.9	136	1"	75	75	60	9	120 PCD	8 x 9	14
3-40-4738-6	1028	920	962	88.9	136	1"	75	75	60	9	120 PCD	8 x 9	17
3-60-4738-8	1536	1428	1470	88.9	136	1"	75	75	60	9	120 PCD	8 x 9	23
4-32-4739-5	826	698	760	114.3	160	1 1/2"	90	90	80	9	144 PCD	8 x 9	20
4-40-4739-6	1028	900	962	114.3	160	1 1/2"	90	90	80	9	144 PCD	8 x 9	23
4-60-4739-8	1536	1408	1470	114.3	160	1 1/2"	90	90	80	9	144 PCD	8 x 9	32
5-32-4740-5	826	688	760	141.3	194	2"	105	105	100	11	174 PCD	8 x 11	28
5-40-4740-6	1028	890	962	141.3	194	2"	105	105	100	11	174 PCD	8 x 11	32
5-60-4740-8	1536	1398	1470	141.3	194	2"	105	105	100	11	174 PCD	8 x 11	45

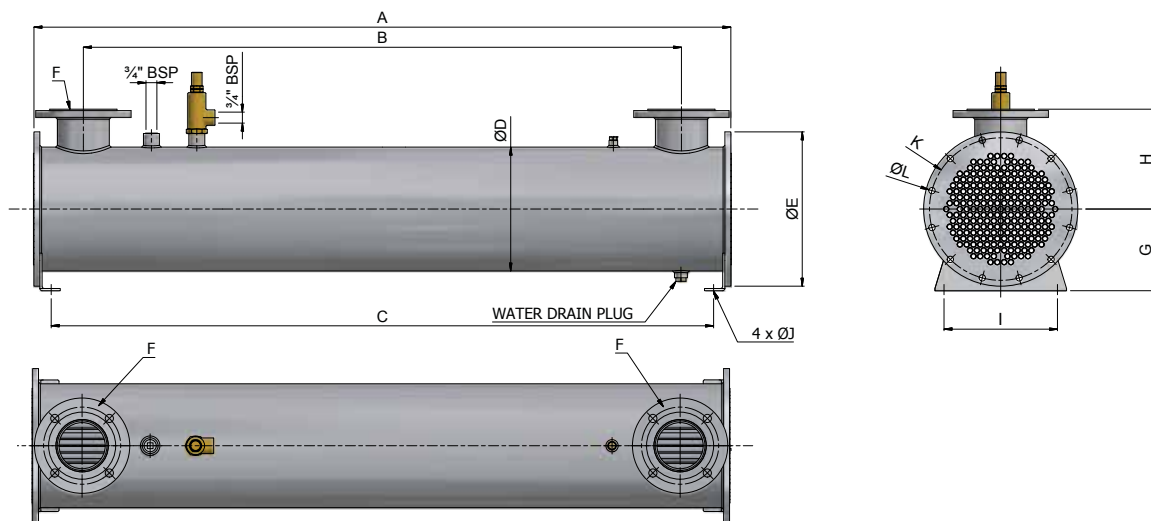

Type	A mm	B mm	C mm	D mm	E mm	F	G mm	H mm	I mm	J mm	K	L	kg
6-32-4741-5	826	668	760	168.3	220	DN65	120	140	130	11	200 PCD	8 x 11	40
6-40-4741-6	1028	870	962	168.3	220	DN65	120	140	130	11	200 PCD	8 x 11	47
6-60-4741-8	1536	1378	1470	168.3	220	DN65	120	140	130	11	200 PCD	8 x 11	65
8-32-4742-5	826	648	750	219	284	DN80	150	180	180	14	260 PCD	8 x 14	66
8-40-4742-6	1028	850	952	219	284	DN80	150	180	180	14	260 PCD	8 x 14	74
8-60-4742-8	1536	1358	1460	219	284	DN80	150	180	180	14	260 PCD	8 x 14	102
10-32-4743-5	826	608	750	273	340	DN100	180	220	250	14	314 PCD	12 x 14	94
10-40-4743-6	1028	810	952	273	340	DN100	180	220	250	14	314 PCD	12 x 14	108
10-60-4743-8	1536	1318	1460	273	340	DN100	180	220	250	14	314 PCD	12 x 14	148
12-32-4744-5	826	538	736	324	410	DN125	220	260	300	18	376 PCD	12 x 18	132
12-40-4744-6	1028	740	938	324	410	DN125	220	260	300	18	376 PCD	12 x 18	151
12-60-4744-8	1536	1248	1446	324	410	DN125	220	260	300	18	376 PCD	12 x 18	210
15-32-4745-5	826	538	710	406.4	495	DN150	280	320	350	18	460 PCD	16 x 18	200
15-40-4745-6	1028	740	912	406.4	495	DN150	280	320	350	18	460 PCD	16 x 18	231
15-60-4745-8	1536	1248	1420	406.4	495	DN150	280	320	350	18	460 PCD	16 x 18	316

Straight end covers

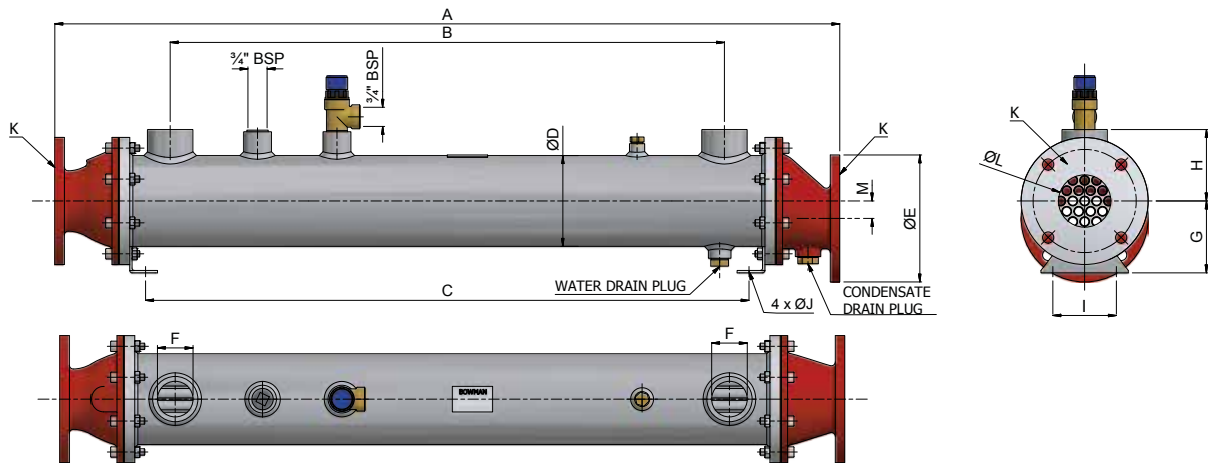

Type	A mm	B mm	C mm	D mm	E mm	F BSP	G mm	H mm	I mm	J mm	K	L	M	kg
2-25-3737-4	750	550	588	60.3	100	3/4"	65	55	60	9	DN25	34	12	10
2-32-3737-5	928	728	766	60.3	100	3/4"	65	55	60	9	DN25	34	12	12
3-32-3738-5	960	718	760	88.9	140	1"	75	75	60	9	DN50	54	16	18
3-40-3738-6	1162	920	962	88.9	140	1"	75	75	60	9	DN50	54	16	20
3-60-3738-8	1670	1428	1470	88.9	140	1"	75	75	60	9	DN50	54	16	27
4-32-3739-5	990	698	760	114.3	160	1 1/2"	90	90	80	9	DN65	66	22	25
4-40-3739-6	1192	900	962	114.3	160	1 1/2"	90	90	80	9	DN65	66	22	29
4-60-3739-8	1700	1408	1470	114.3	160	1 1/2"	90	90	80	9	DN65	66	22	40
5-32-3740-5	1030	688	760	141.3	190	2"	105	105	100	11	DN80	82	26	36
5-40-3740-6	1232	890	962	141.3	190	2"	105	105	100	11	DN80	82	26	39
5-60-3740-8	1740	1398	1470	141.3	190	2"	105	105	100	11	DN80	82	26	51

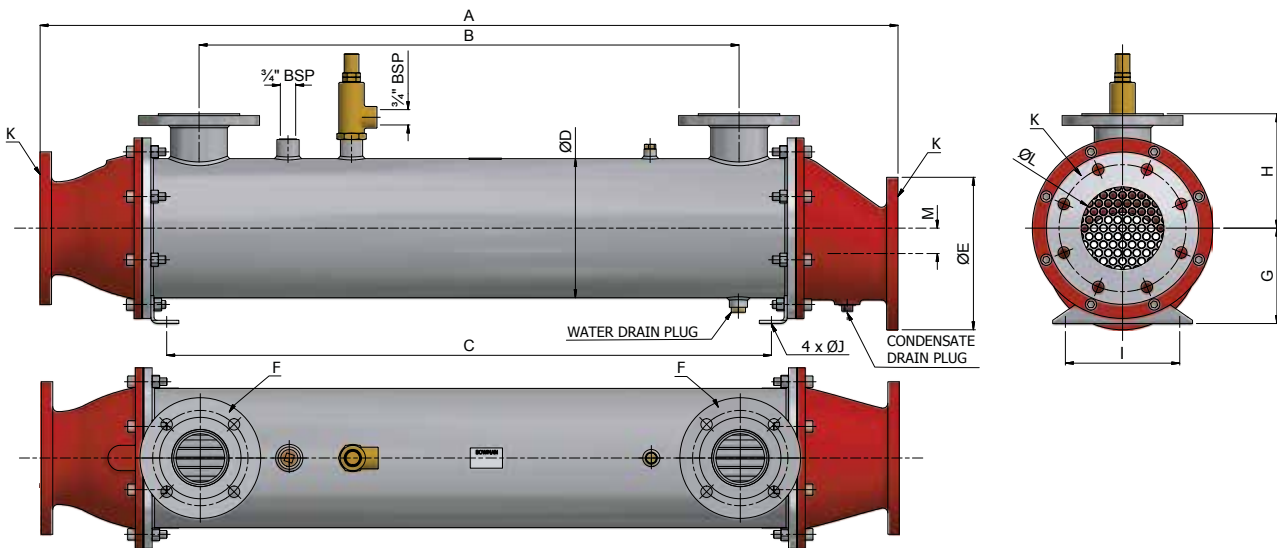

Type	A mm	B mm	C mm	D mm	E mm	F	G mm	H mm	I mm	J mm	K	L mm	M mm	kg
6-32-3741-5	1080	668	760	168.3	210	DN65	120	140	130	11	DN100	104	28	48
6-40-3741-6	1282	870	962	168.3	210	DN65	120	140	130	11	DN100	104	28	55
6-60-3741-8	1790	1378	1470	168.3	210	DN65	120	140	130	11	DN100	104	28	72
8-32-3742-5	1150	648	750	219	240	DN80	150	180	180	14	DN125	130	40	89
8-40-3742-6	1352	850	952	219	240	DN80	150	180	180	14	DN125	130	40	98
8-60-3742-8	1860	1358	1460	219	240	DN80	150	180	180	14	DN125	130	40	125
10-32-3743-5	1230	608	750	273	265	DN100	180	220	250	14	DN150	154	55	132
10-40-3743-6	1432	810	952	273	265	DN100	180	220	250	14	DN150	154	55	146
10-60-3743-8	1940	1318	1460	273	265	DN100	180	220	250	14	DN150	154	55	185
12-32-3744-5	1330	538	736	324	320	DN125	220	260	300	18	DN200	204	55	190
12-40-3744-6	1532	740	938	324	320	DN125	220	260	300	18	DN200	204	55	208
12-60-3744-8	2040	1248	1446	324	320	DN125	220	260	300	18	DN200	204	55	268
15-32-5745-5	1468	538	710	406.4	375	DN150	280	320	350	18	DN250	254	70	288
15-40-5745-6	1670	740	912	406.4	375	DN150	280	320	350	18	DN250	254	70	319
15-60-5745-8	2180	1248	1420	406.4	375	DN125	280	320	350	18	DN250	254	70	404

Right angle end covers

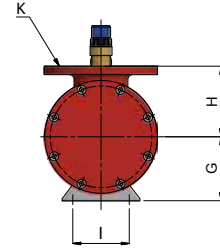
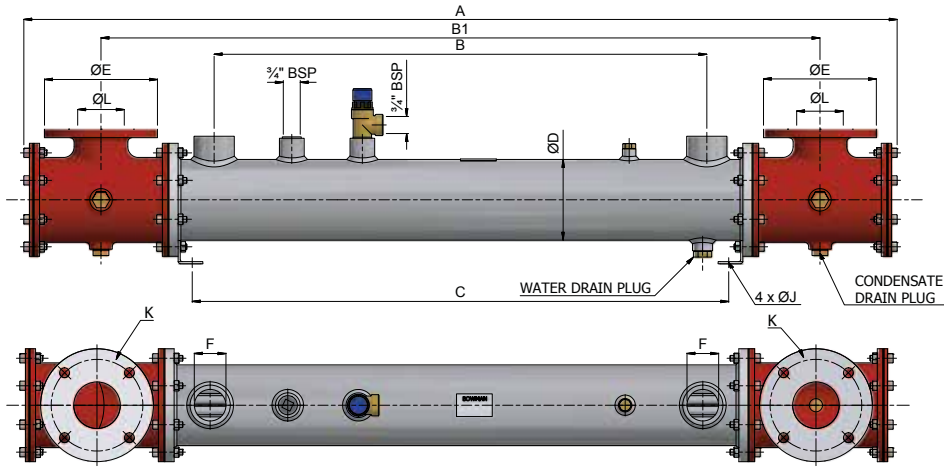

Type	A mm	B mm	B1 mm	C mm	D mm	E mm	F BSP	G mm	H mm	I mm	J mm	K	L mm	kg
2-25-5837-4	920	550	770	588	60.3	100	3/4"	65	70	60	9	DN25	34	13
2-32-5837-5	1098	728	950	760	60.3	100	3/4"	65	70	60	9	DN25	34	14
3-32-5838-5	1198	718	999	760	88.9	140	1"	75	85	60	9	DN50	54	24
3-40-5838-6	1400	920	1200	962	88.9	140	1"	75	85	60	9	DN50	54	27
3-60-5838-8	1908	1428	1708	1470	88.9	140	1"	75	85	60	9	DN50	54	33
4-32-5839-5	1237	698	1019	760	114.3	160	1 1/2"	90	100	80	9	DN65	66	33
4-40-5839-6	1439	900	1221	962	114.3	160	1 1/2"	90	100	80	9	DN65	66	37
4-60-5839-8	1948	1408	1729	1470	114.3	160	1 1/2"	90	100	80	9	DN65	66	46
5-32-5840-5	1306	688	1049	760	141.3	190	2"	105	120	100	11	DN80	82	51
5-40-5840-6	1504	890	1251	962	141.3	190	2"	105	120	100	11	DN80	82	55
5-60-5840-8	2010	1398	1759	1470	141.3	190	2"	105	120	100	11	DN80	82	68

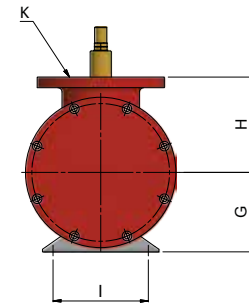
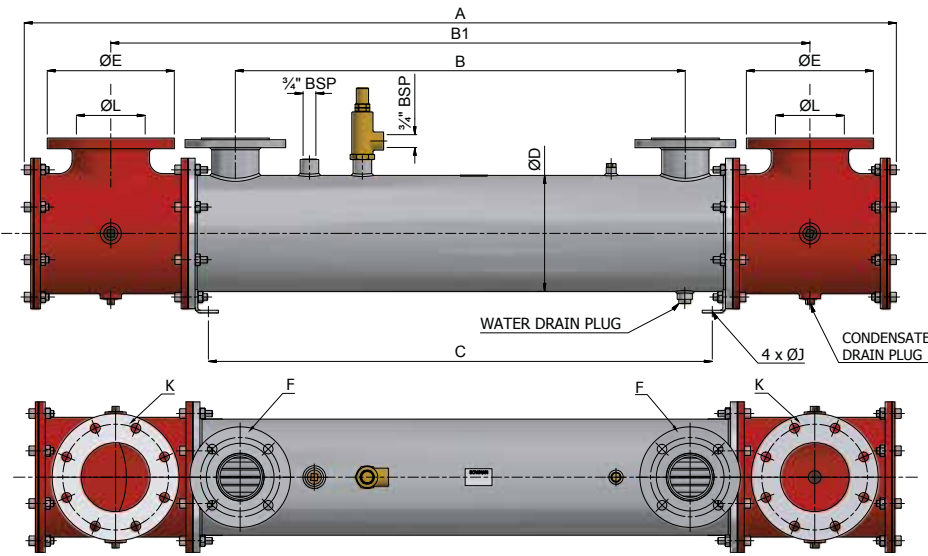

Type	A mm	B mm	B1 mm	C mm	D mm	E mm	F	G mm	H mm	I mm	J mm	K	L mm	kg
6-32-5841-5	1400	668	1100	760	168.3	210	DN65	120	140	130	11	DN100	104	72
6-40-5841-6	1604	870	1302	962	168.3	210	DN65	120	140	130	11	DN100	104	79
6-60-5841-8	2110	1378	1810	1470	168.3	210	DN65	120	140	130	11	DN100	104	96
8-32-5842-5	1446	648	1120	750	219	240	DN80	150	180	180	14	DN125	130	119
8-40-5842-6	1648	850	1322	952	219	240	DN80	150	180	180	14	DN125	130	128
8-60-5842-8	2156	1358	1830	1460	219	240	DN80	150	180	180	14	DN125	130	155
10-32-5843-5	1528	608	1159	750	273	265	DN100	180	220	250	14	DN150	154	180
10-40-5843-6	1730	810	1361	952	273	265	DN100	180	220	250	14	DN150	154	193
10-60-5843-8	2238	1318	1869	1460	273	265	DN100	180	220	250	14	DN150	154	234
12-32-5844-5	1720	538	1249	736	323.9	320	DN125	220	260	300	18	DN200	204	272
12-40-5844-6	1920	740	1451	938	323.9	320	DN125	220	260	300	18	DN200	204	292
12-60-5844-8	2430	1248	1959	1446	323.9	320	DN125	220	260	300	18	DN200	204	348
15-32-5845-5	1880	538	1329	710	406.4	375	DN150	280	320	350	18	DN250	254	395
15-40-5845-6	2082	740	1531	912	406.4	375	DN150	280	320	350	18	DN250	254	428
15-60-5845-8	2590	1248	2039	1420	406.4	375	DN150	280	320	350	18	DN250	254	513

Installation Guidelines

IMPORTANT: Please follow these guidelines when designing an exhaust gas heat recovery installation.

1. Bowman exhaust gas heat exchangers should be installed horizontally and levelled accurately with the water connections on top, so that they are always full of water.
2. The heat exchanger should be connected for counter flow so that the cooling medium flows in the opposite direction to the exhaust gas stream. Please see below for reference.
3. The heat exchanger should be installed below the level of the cylinder head, so that in the unlikely event of a tube leak occurring, water will not leak back into the engine.
4. **IMPORTANT:** the water circuit must be fully vented via the vent plug to prevent the possibility of air pockets being present or aeration taking place.
5. If ethylene glycol, or any other cooling medium is used in the water circuit, use the correct concentration advised by the engine manufacturer.
6. Automatic engine shutdown equipment must be provided with temperature probes in the exhaust gas heat exchanger and the engine.
7. Under no circumstances should the pressure relief valve be removed or tampered with.
8. The inlet and exit exhaust pipe bore must not be smaller than the heat exchanger connections.

Operation Guidelines

1. Should the exhaust gas circuit be shut down, it is important to ensure that the water circuit continues to operate for a period of time to enable residual heat to disperse from within the heat exchanger, to prevent the possibility of damage.
2. It is important to ensure that the water circuit pumps operate continually whenever the exhaust gas circuit is in operation, to prevent the possibility of damage to the unit through overheating.
3. It is also important to ensure that any valves or ancillary equipment fitted to the heat exchanger cannot be accidentally turned off, preventing water flow through the heat exchanger.
4. Bowman exhaust gas heat exchangers are designed for engine applications to be run in 'steady state' operating mode. It is not recommended to install the heat exchanger on engines that run in 'transient cycle' operating mode, as the constant thermal variation can create stresses within the structure, leading to premature failure.

If you are in any doubt as to the nature of the installation, please contact our technical sales team who will be able to provide further information and guidance.

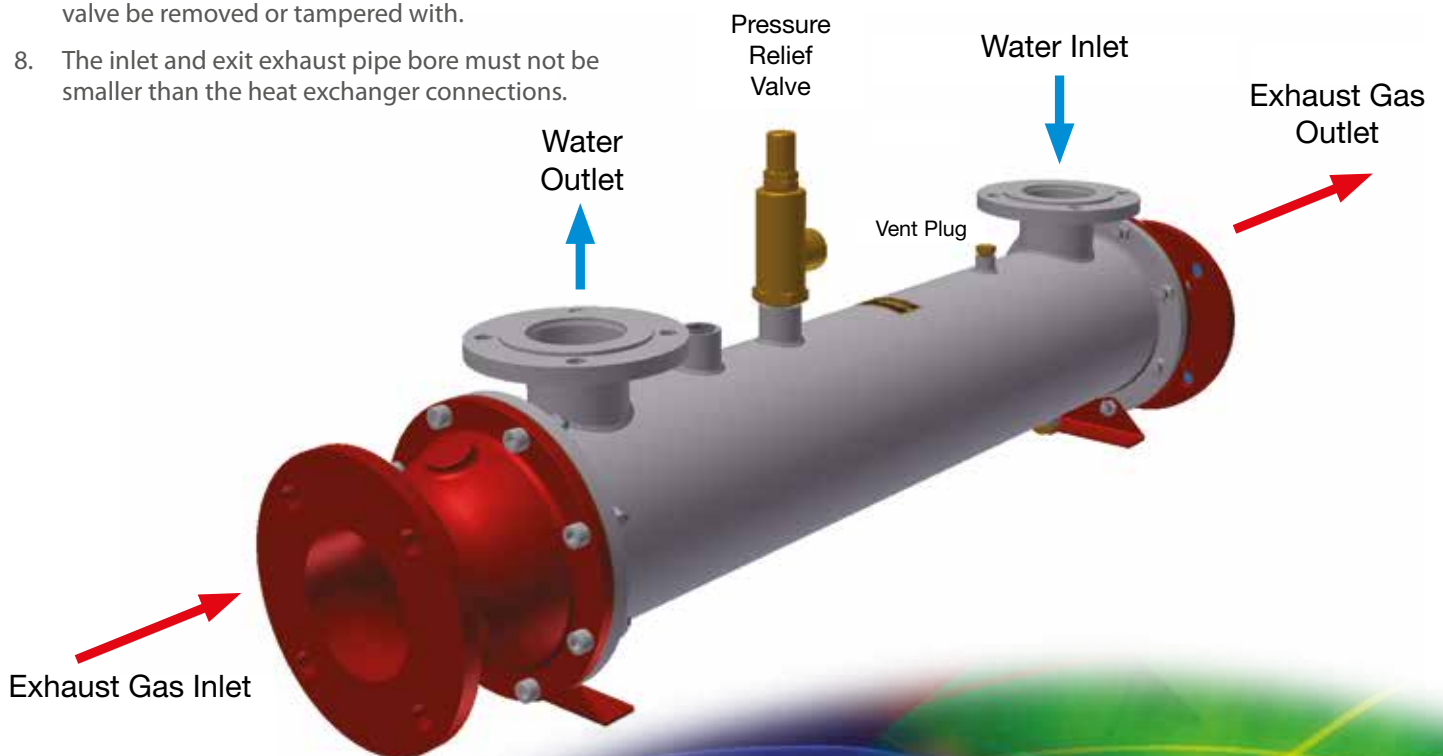

Servicing the unit

Simply unbolting the end covers or access plates (depending on the version) allows access to the tube plates, which can then be easily cleaned in accordance with guide lines given in the Installation, Operation and Maintenance Manual.



NOTE: on reassembly, new gaskets should always be used when refitting end covers or access plates.

Replacement Parts

A comprehensive range of replacement parts is available including end covers, gaskets, pressure relief valves, end cover fixings, feet and drain plugs.

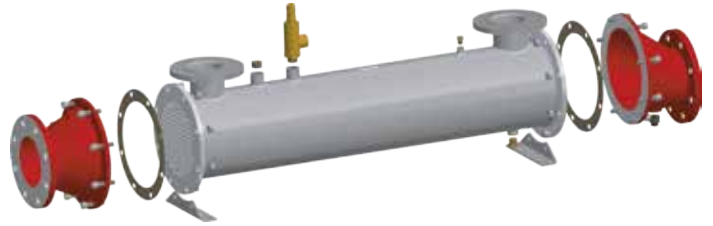

Total Engine Cooling Solutions

For nearly 100 years, Bowman has provided efficient, reliable cooling solutions for normally aspirated and forced induction engines. During that time the company has amassed a wealth of expertise and can provide a complete cooling solution for both marine and land based stationary engines, including:

Header Tank Heat Exchangers

Bowman's unique design combines high efficiency engine cooling, with long life durability. Suitable for engines up to 1800kW.



Engine & Gearbox Oil Coolers

A range of compact units suitable for engine or transmission oil cooling.



Charge Air Coolers

Improved combustion efficiency and reduced fuel consumption are just some of the benefits provided by Bowman charge air coolers.



Fuel Coolers

Bowman in line plate fuel coolers are compact, easy to install and suitable for use with all fuel types – including Ethanol rich fuels



Combined heat recovery performance table

Type	Engine Power	Jacket Water	Engine Oil	Charge Air Cooler	Exhaust Gas	Total Reclaimed Energy
	kW	kW	kW	kW	kW	kW
2-	16	5	2	2.5	11.5	20.5
3-	32	10	4	5	23	41
4-	60	18	7	9	43	77
5-	90	27	10	14	65	115
6-	140	42	15	21	101	179
8-	250	75	28	38	181	321
10-	400	120	44	60	288	512
12-	600	180	66	90	425	761
15-	950	280	104	142	670	1205

The figures should be used as a guide only, and an optimised design is available on request.

All material contained in this brochure is the intellectual property of EJ Bowman (Birmingham) Ltd. It is protected under copyright and may not be reproduced without prior written consent of the company.

Achieving 80% Gen-set efficiency

Simply by recovering waste heat from your engine, overall gen-set efficiency can be increased to **80%*** ...and beyond!

Up to 50% ** of all fuel input into the gen-set can be recovered and used as valuable heat energy.

This valuable energy source can be harvested and used at no additional cost, in terms of fuel used or CO₂ generated.

And it can be used for a wide range of domestic, commercial or industrial uses, including district heating and hot water, space heating, process heating, generating electricity, or running a chiller for cooling.

By recovering waste heat energy, overall gen-set efficiency can be increased from around 30% (power only) to 80% (combined heat and power), or even more.

Waste heat recovery potential

Waste heat can be recovered from most areas of an engine powered gen-set, taking it from power only, to a highly efficient CHP facility.

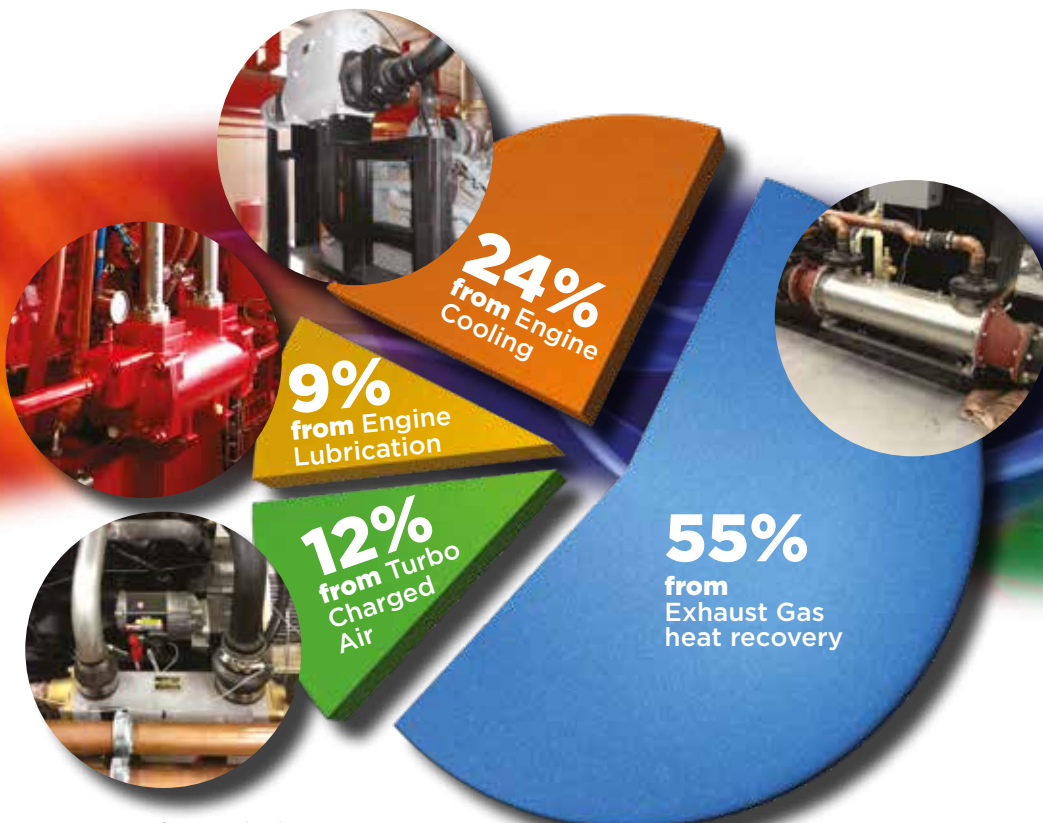
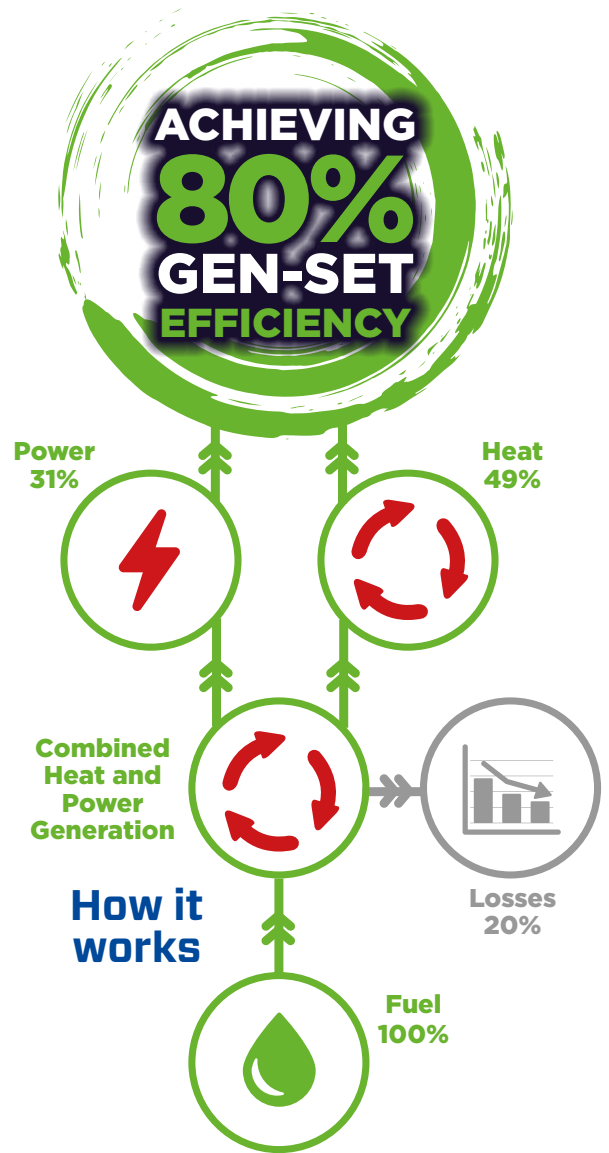

*Association of Decentralised Energy

**Digest of United Kingdom Energy Statistics (DUKES) 2015

A world of applications

Bowman exhaust gas heat exchangers can be found recovering valuable waste heat energy in some of the most diverse and technically challenging applications around the world. Here are just a few examples:



In the **Antarctic**, Bowman exhaust gas heat exchangers are a vital part of a CHP system that supplies lifesaving energy to the British Antarctic Survey's research station, Halley VI, where winter temperatures plummet to - 50° C, snow falls for half the year and the station is literally cut off throughout the winter period.



In **Finland**, a new 'closed loop' grain drying system, using Bowman waste heat recovery technology, has significantly reduced energy costs for this traditionally energy intensive operation. In the first year since installation, the system has reduced fuel consumption at a Finnish farm by half – saving around 18,000 litres of diesel per year!



As demand for electrical power increases, Bowman exhaust gas units are being used on leading edge technologies that capture waste heat and convert it into more electricity. In the **USA**, Bowman heat exchangers are at the heart of ground breaking technology, designed to increase gen-set efficiency and reduce fuel consumption.



In the Northwest Territories of **Canada**, Bowman heat exchangers have been installed as part of a new cogeneration system that has halved energy costs for the remote community of Fort Providence, where winter temperatures regularly fall to - 40° C.



All Bowman exhaust gas heat exchangers are produced to the highest quality in our dedicated UK manufacturing centre, to ISO 9001:2008 standards. With over 50 years' experience producing highly efficient waste heat recovery solutions, you can have complete confidence when you specify Bowman exhaust gas heat exchangers.

mdt

authorised regional warehouse & distributor of E.J. Bowman (U.K.)

www.mdtco.com

info@mdtco.com

BOWMAN[®]
100 YEARS OF HEAT TRANSFER TECHNOLOGY



FM38224

EJ Bowman (Birmingham) Ltd, reserve the right to change specifications without prior notice.