

# MSG

HEAT EXCHANGERS  
WITH  
REMOVABLE TUBE BUNDLE



**sesino**

HEAT EXCHANGING EXCELLENCE SINCE 1919

NEW LINE

MSG 84 E 134

MSG 84 E 134

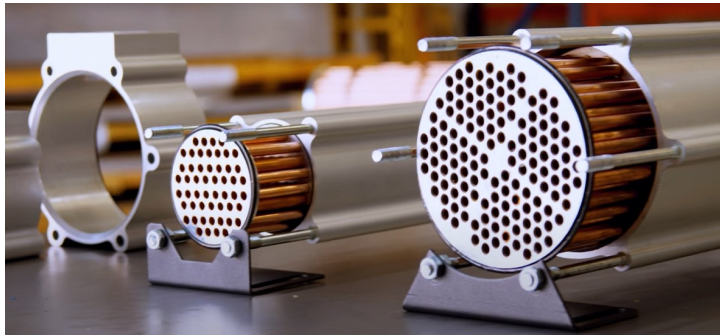
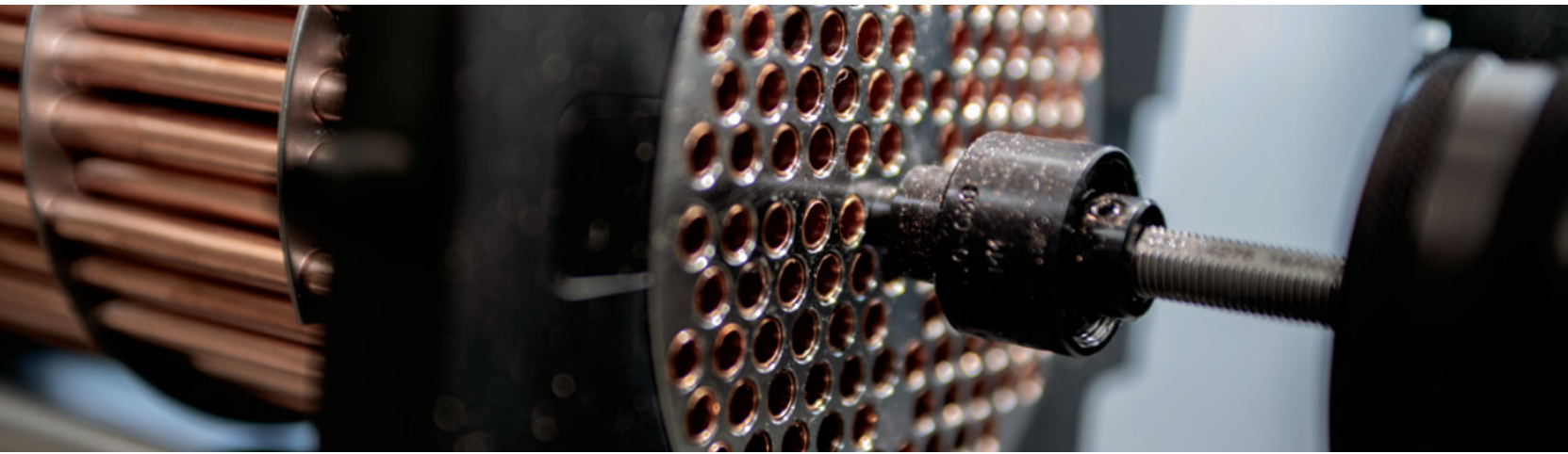

introducing  
advanced design  
&  
high thermic performance  
in heat transfer technology

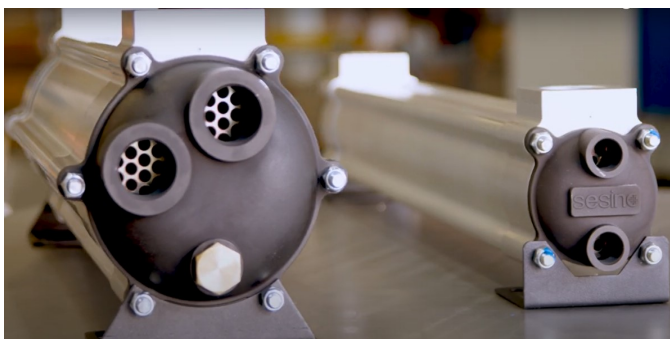

- Compared to our current heat exchangers, for this line we made a choice of environmental sustainability; we eliminated all the welding and the consequent fumes caused by flames and fluxes that must be sucked from the work environment. We eliminated the subsequent washing operations that generate dirty water to be treated as special waste. This way we could ensure a better work environment for our employees and no environmental pollution.

- The welding of the tubes to the tube sheets have been replaced by an automated precision tube expanding, that ensures a high-quality level of the coupling and a constant production.

100% of the expanded tube bundles are pressure tested, as well as the 100% of the finished exchangers are pressure tested.

- The MSG heat exchangers have a removable tube bundle that is very easy to assemble and disassemble or replace it with a new one.

- The accuracy of the mechanical processing with very close tolerances and use of special seals allowed us to increase the thermic performance of around 10-15 % for the same external dimensions; the new line design is protected by patent already filed.

- The MSG line is perfectly interchangeable with the old MS line

- Shell, manifolds and covers are not painted but anodised, gaining this way a better protection.

The materials that make up the new line are the following:

- **Tube-bundle tubes: copper**
- **Tube sheets: hardened steel**
- **Shell: extruded anodised aluminium**
- **Covers: anodized die-cast aluminum**
- **Seals Kit: viton**

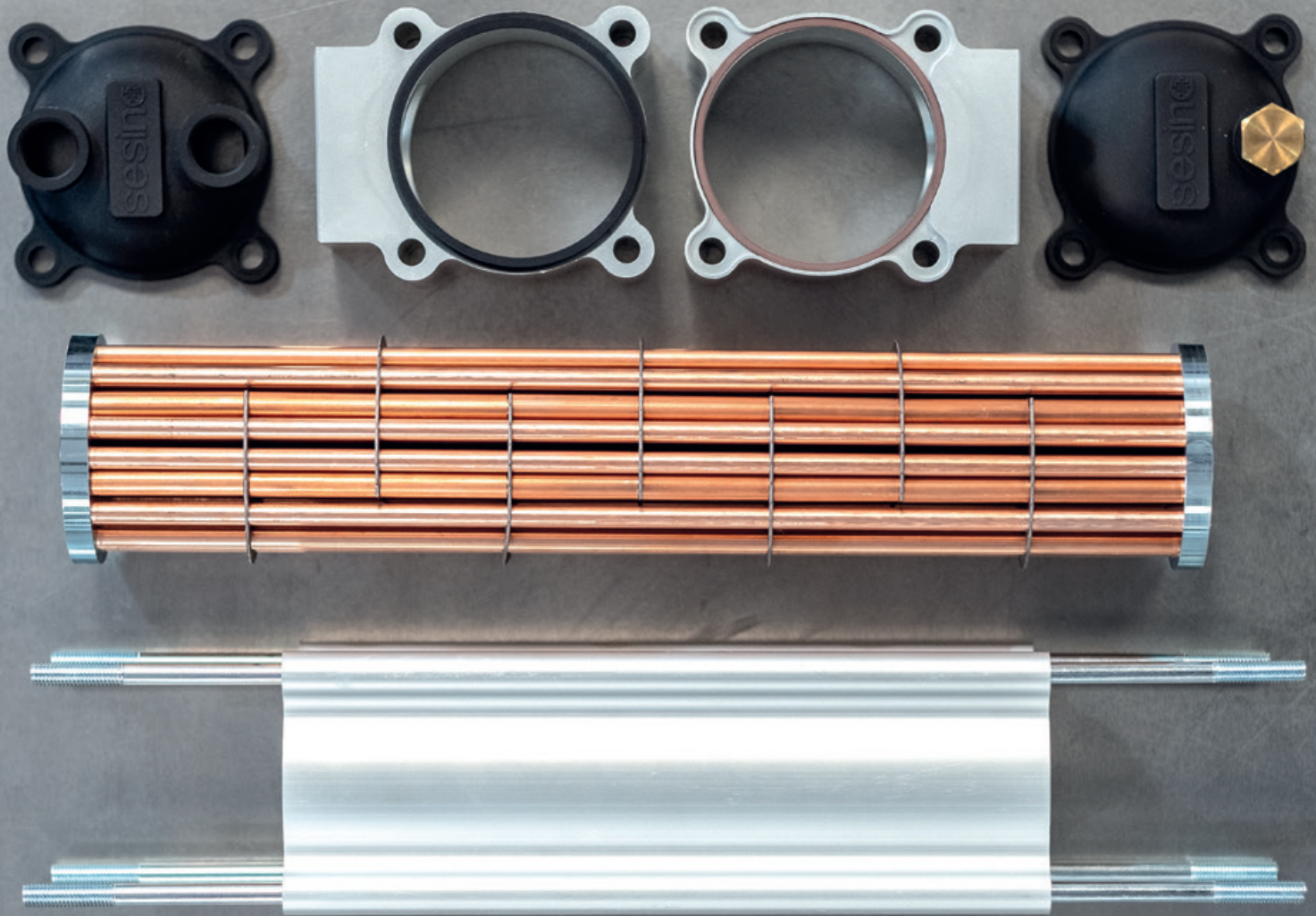

## LEGENDA

1. FASCIO TUBIERO - *TUBE BUNDLE*
2. TUBI FASCIO - *BUNDLE TUBES*
3. PIASTRE TUBIERE - *TUBE SHEETS*
4. MANTELLO - *SHELL*
5. COLLETTORI MANTELLO - *SHELL MANIFOLDS*
6. TESTATA - *HEAD COVER*
7. FONDO - *END COVER*
8. SUPPORTI FISSAGGIO - *FIXING SUPPORTS*
9. VITI PRIGIONIERE - *STUD SCREW*
11. DADI - *NUTS*
12. TAPPO CON ANODO - *ANODE PLUG*
13. KIT GUARNIZIONI - *SEALS KIT*

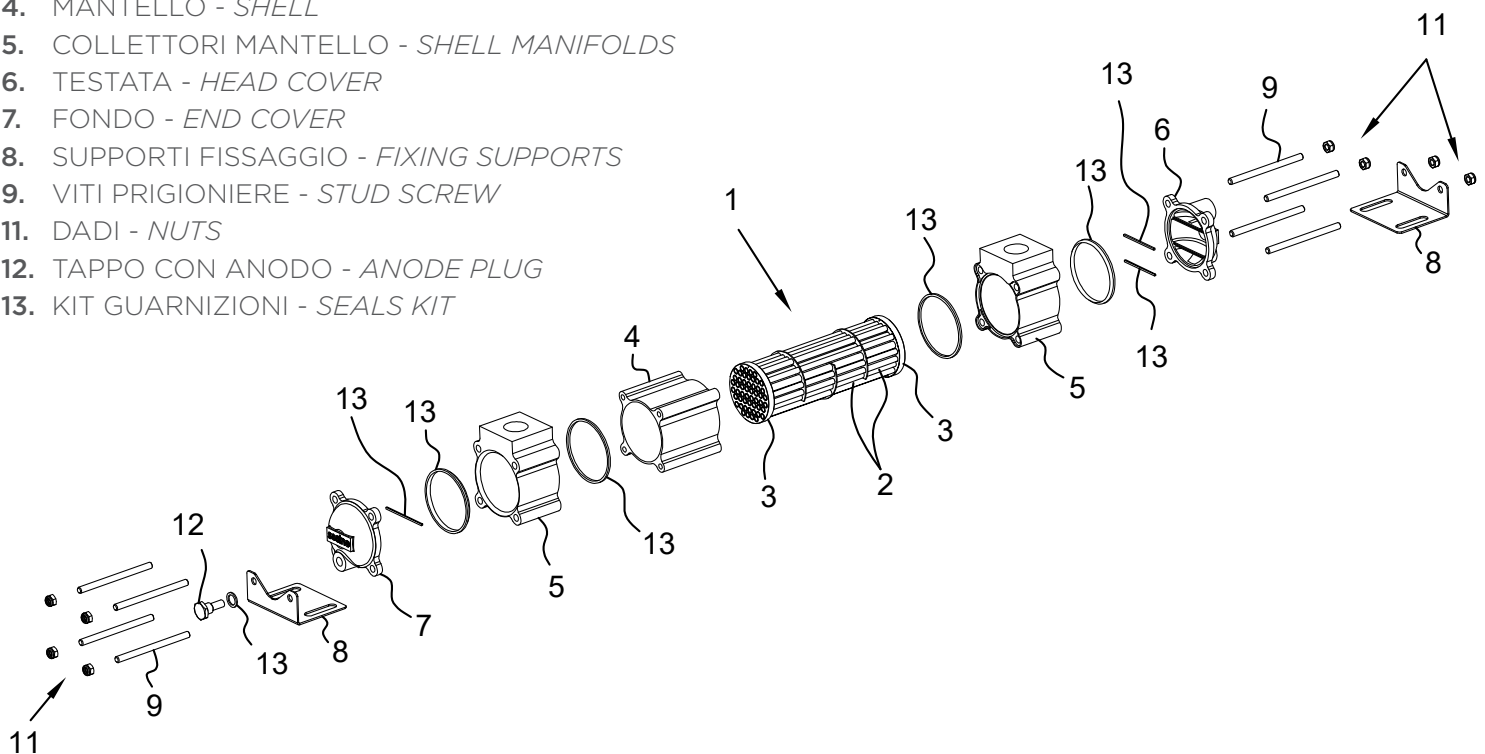

# MSG 84

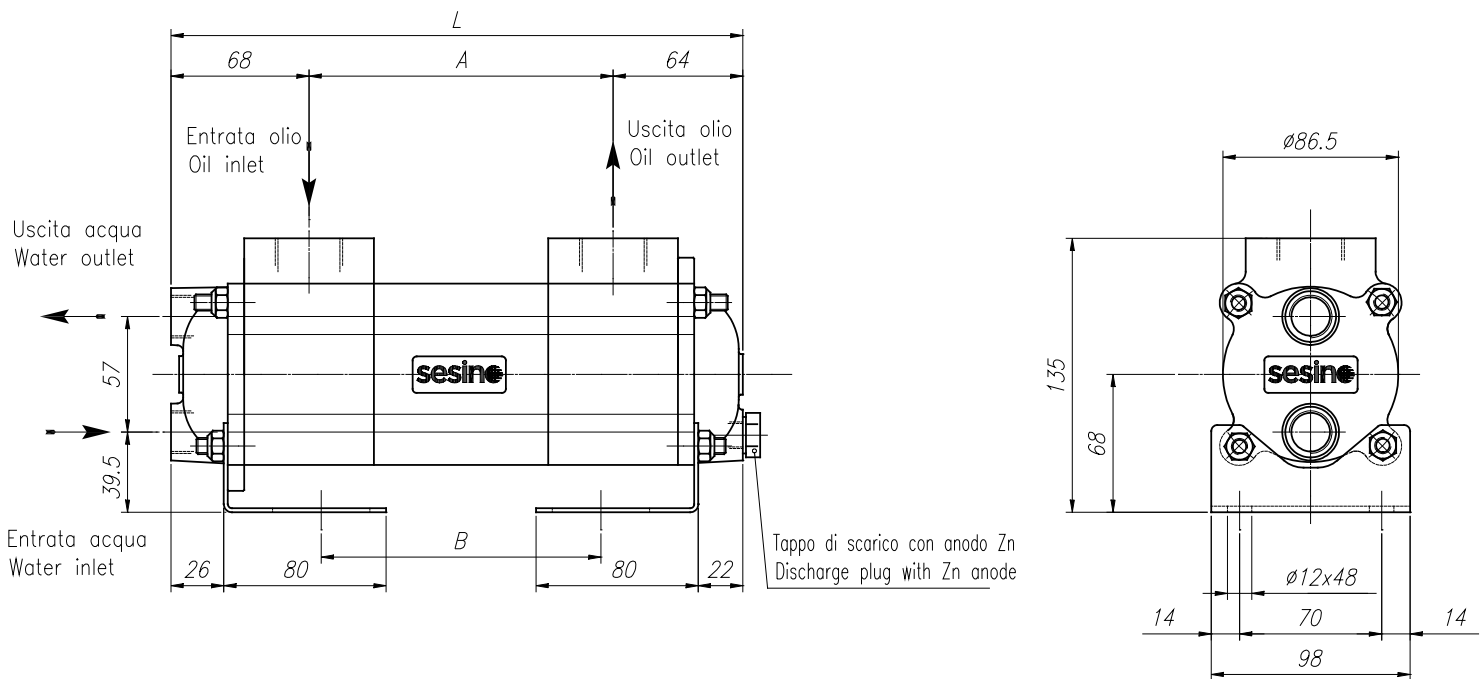

## Potenza termica scambiata a $\Delta T_{in}=25^{\circ}\text{C}$ Heat exchanged a $\Delta T_{in}=25^{\circ}\text{C}$ [kW] Connessioni Connections

Tipo Type	Codice Code	Portata acqua Water flow [l/min]	Portata olio Oil flow [l/min]	min. acqua, min. olio min. water, min. oil flow	min. acqua, max. olio min. water, max. oil flow	max. acqua, min. olio max. water, min. oil flow	max. acqua, max. olio max. water, max. oil flow	Acqua Water	Olio Oil	Interasse connessioni olio Oil connections distance A [mm]	Interasse fori fissaggio Anchor point distance B [mm]	Lunghezza Length L [mm]	Peso Weight [kg]
<b>MSG 84 P1</b>	2SCG84P1	7,5 - 30	30-80	2	3	3	5	G½	G1	150	102-174	282	4,5
<b>MSG 84 P2</b>	2SCG84P2	7,5 - 30	20-60	3	4	4	6	G½	G1	310	262-334	442	6,3
<b>MSG 84 P3</b>	2SCG84P3	7,5 - 30	50-100	4	5	5	9	G½	G1-½	310	262-334	442	6,5
<b>MSG 84 P4</b>	2SCG84P4	7,5 - 30	30-80	5	8	7	11	G½	G1	560	512-584	692	9
<b>MSG 84 P5</b>	2SCG84P5	7,5 - 30	80-130	7	8	8	10	G½	G1-½	560	512-584	692	9
<b>MSG 84 P6</b>	2SCG84P6	7,5 - 30	40-90	10	13	13	20	G½	G1-½	715	667-739	847	10,8
<b>MSG 84 P7</b>	2SCG84P7	7,5 - 30	100-160	12	15	17	23	G½	G1-½	715	667-739	847	10,9
<b>MSG 84 P8</b>	2SCG84P8	7,5 - 30	60-110	13	18	18	26	G½	G1-½	870	822-894	1002	12,3
<b>MSG 84 P9</b>	2SCG84P9	7,5 - 30	140-190	17	19	23	30	G½	G1-½	870	822-894	1002	12,3

WATER FLOW RATE:



CONSTRUCTION MATERIALS

SHELL	TUBES	END COVERS
ALLUMINIUM	COPPER	ALLUMINIUM

P1 P2 P3

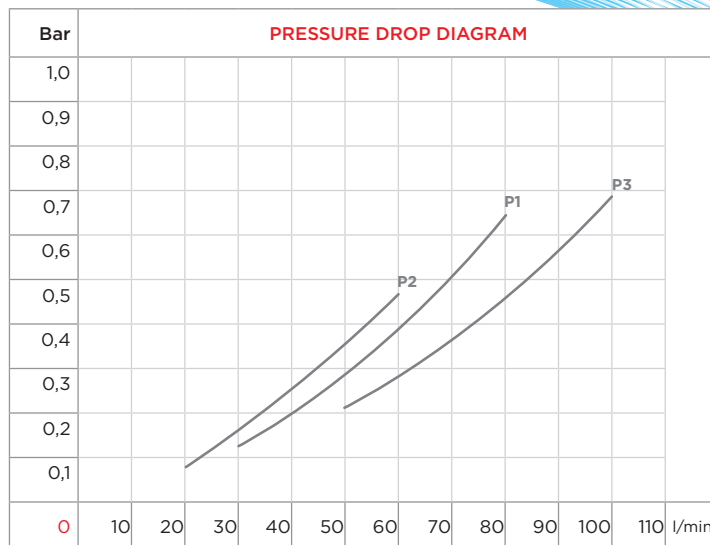
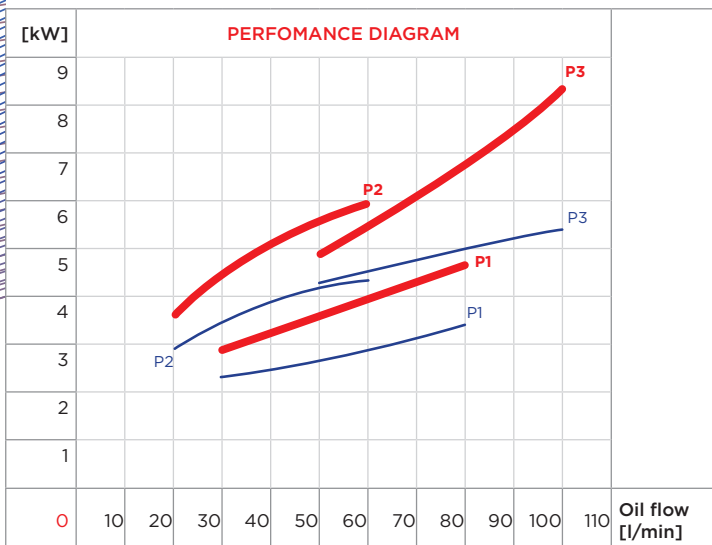

P4 P5 P6

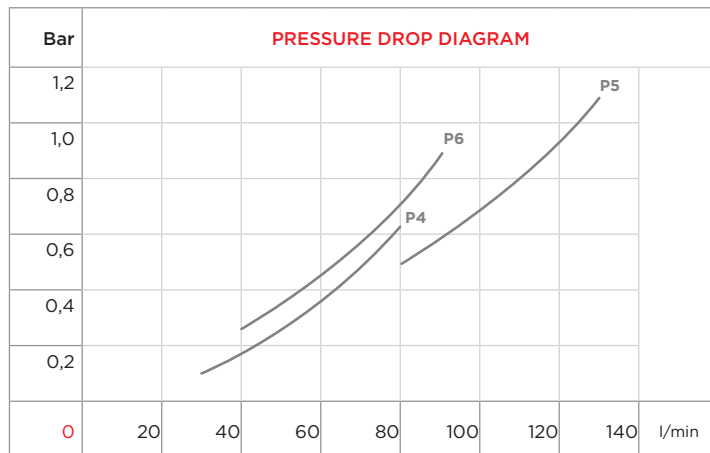
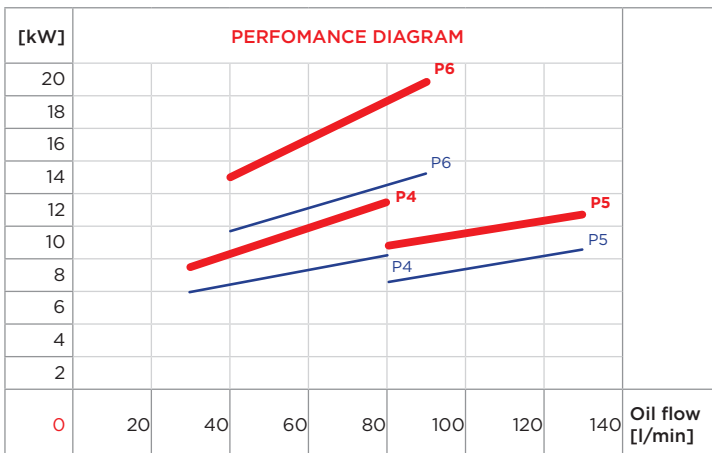

P7 P8 P9

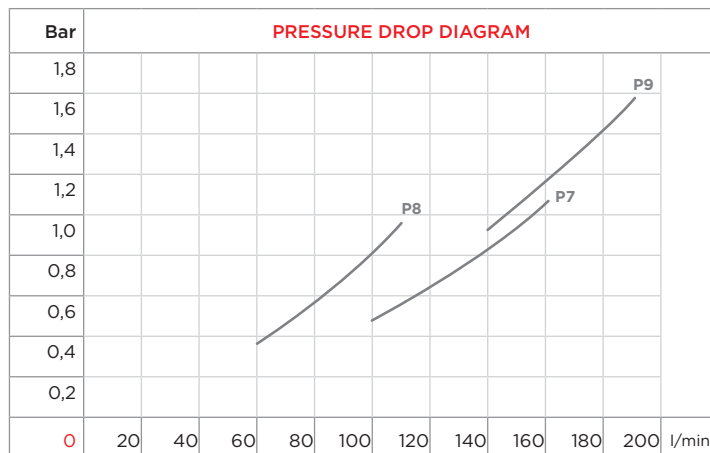
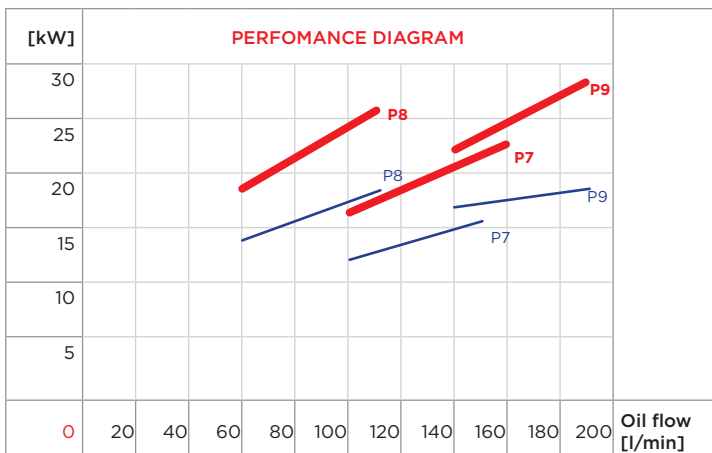

CORRECTION FACTOR

ΔTm	10	15	20	25	30	35	40
f	2,5	1,67	1,25	1	0,83	0,71	0,63

CORRECTION FACTOR

cSt	22	30	46	68	100	150	220
f	0,4	0,6	1	1,5	2,3	3,3	4,6

# MSG 134

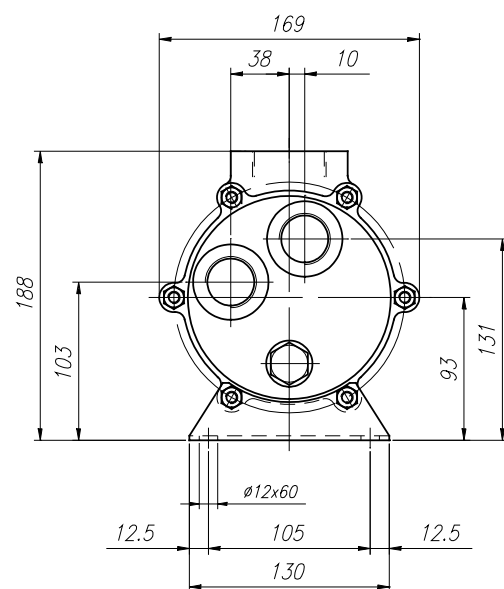
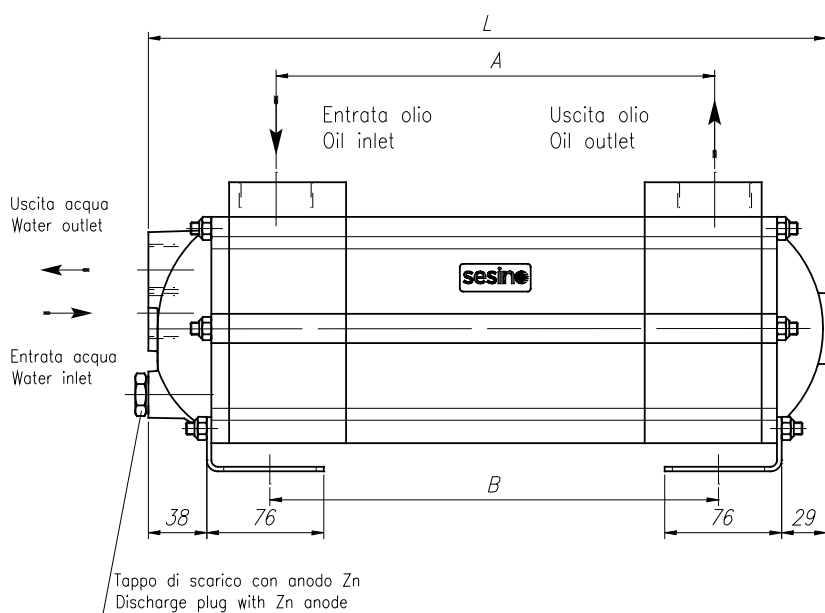
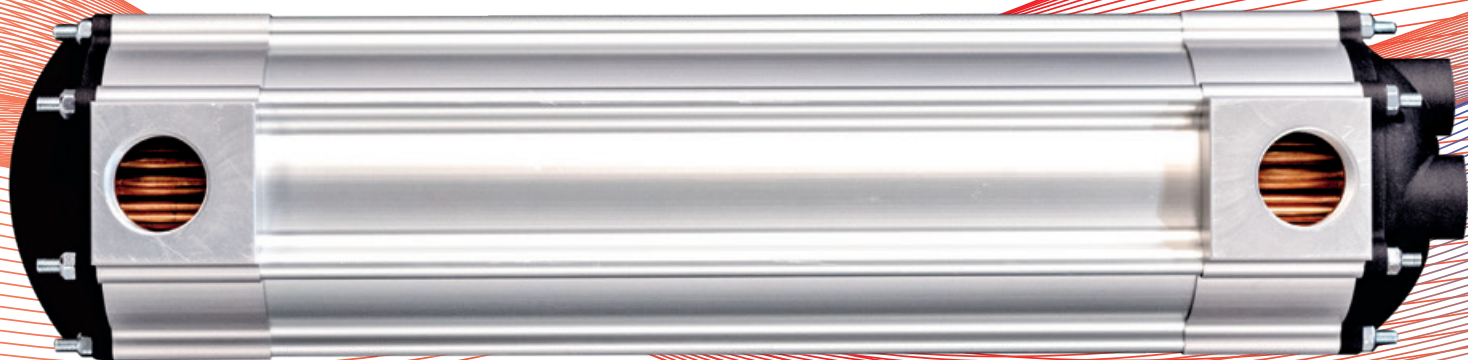

## Potenza termica scambiata a $\Delta T_{in}=25^{\circ}\text{C}$ Heat exchanged a $\Delta T_{in}=25^{\circ}\text{C}$ [kW] Connessioni Connections

Tipo Type	Codice Code	Portata acqua Water flow [l/min]	Portata olio Oil flow [l/min]	min. acqua, min. olio min. water, min. oil flow	min. acqua, max. olio min. water, max. oil flow	max. acqua, min. olio max. water, min. oil flow	max. acqua, max. olio max. water, max. oil flow	Acqua Water	Olio Oil	Interasse connessioni olio Oil connections distance A [mm]	Interasse fori fissaggio Anchor point distance B [mm]	Lunghezza Length L [mm]	Peso Weight [kg]
<b>MSG 134 P1</b>	2SCG134P1	15-60	30-100	4	10	4	13	G1	G1-½	285	243,5-339,5	440,5	16,4
<b>MSG 134 P2</b>	2SCG134P2	15-60	40-130	14	24	19	36	G1	G1-½	535	493,5-589,5	690,5	22,6
<b>MSG 134 P3</b>	2SCG134P3	15-60	120-250	22	28	32	43	G1	G2	520	493,5-589,5	690,5	23
<b>MSG 134 P4</b>	2SCG134P4	15-60	80-250	9	23	10	32	G1	G1-½	845	803,5-899,5	1000,5	30,7
<b>MSG 134 P5</b>	2SCG134P5	15-60	200-400	34	43	53	77	G1	G2	830	803,5-899,5	1000,5	30,9
<b>MSG 134 P6</b>	2SCG134P6	15-60	30-170	12	29	13	40	G1	G1-½	1145	1103,5-1199,5	1300,5	40
<b>MSG 134 P7</b>	2SCG134P7	15-60	200-500	35	70	45	105	G1	G2	1130	1103,5-1199,5	1300,5	39,5

WATER FLOW RATE:



CONSTRUCTION MATERIALS

SHELL	TUBES	END COVERS
ALLUMINIUM	COPPER	ALLUMINIUM

P1 P2 P3

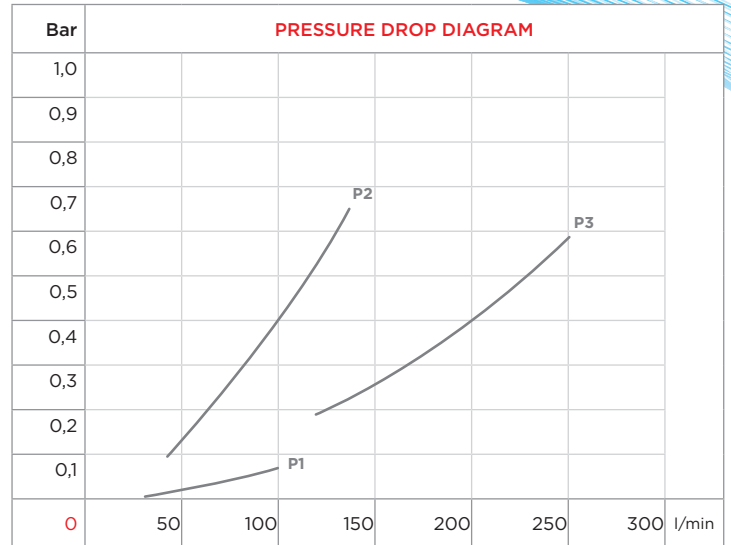
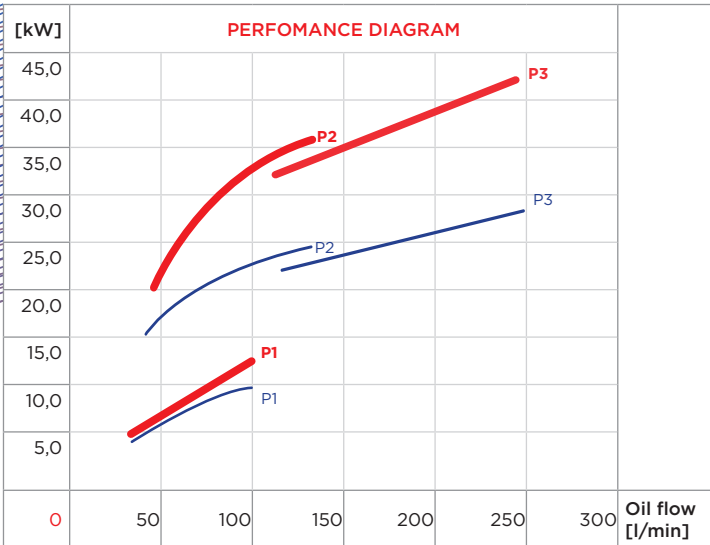

P4 P5 P6

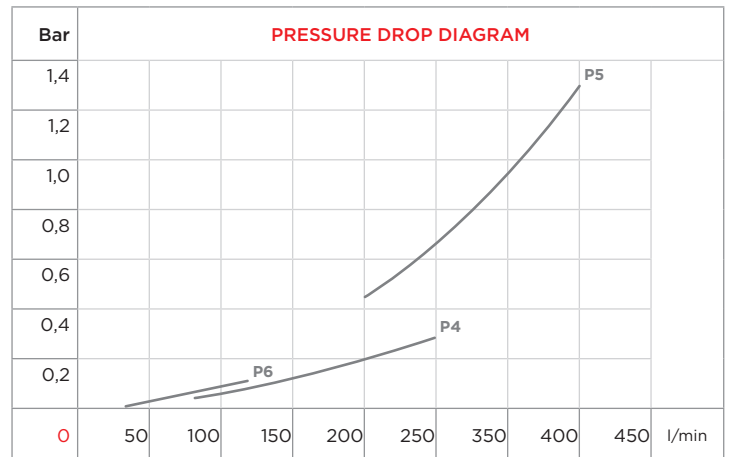
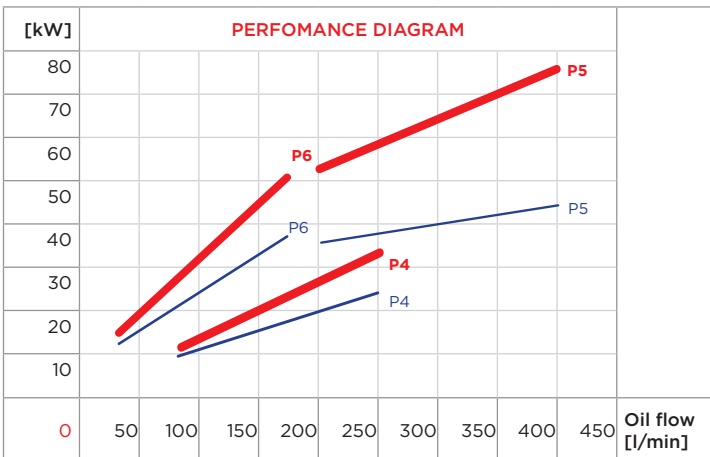

P7

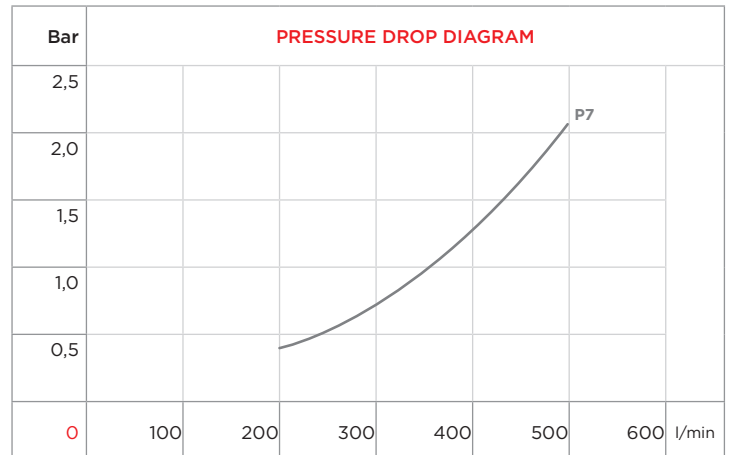
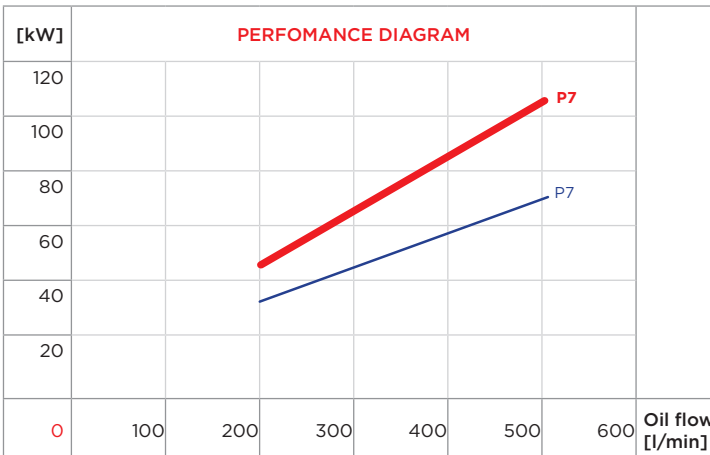

CORRECTION FACTOR

$\Delta T_m$	10	15	20	25	30	35	40
f	2,5	1,67	1,25	1	0,83	0,71	0,63

CORRECTION FACTOR

cSt	22	30	46	68	100	150	220
f	0,4	0,6	1	1,5	2,3	3,3	4,6

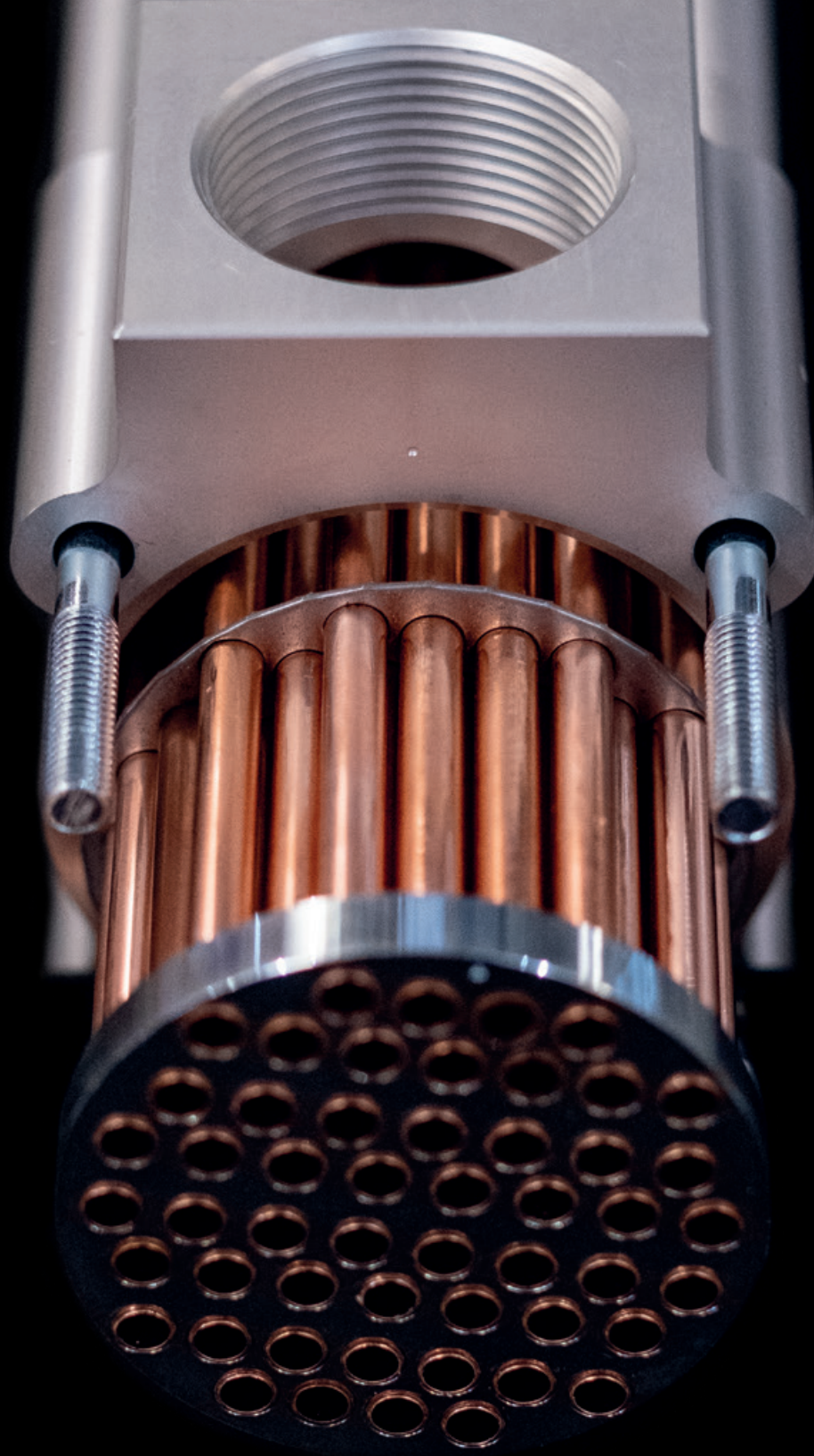

# sesino

HEAT EXCHANGING EXCELLENCE SINCE 1919

MDT co. is authorized regional warehouse & distributor of SESINO products

sesino *mdt*

[www.mdtco.com](http://www.mdtco.com)

[info@mdtco.com](mailto:info@mdtco.com)



Quality Management System



Occupational Health and Safety Assessment Series