

oil coolers and heat exchangers shell & tube type

hydraulic oil coolers



BOWMAN[®]
100 YEARS OF HEAT TRANSFER TECHNOLOGY

for stationary, mobile & marine applications

mdt

authorised regional warehouse
and distributor of EJ.Bowman

www.mdtco.com

Proven durability. On land,

Bowman Hydraulic Oil Coolers

Efficient, reliable heat transfer performance for hydraulic oils, heat transfer fluids, plus lubricating and quenching oils.

Heat exchangers perform a vital role in maintaining the performance and reliability of hydraulic systems.

Excessive temperature will reduce the performance of the system and may lead to component failure.

Maintaining the correct oil temperature extends the useful life of the system, reducing downtime and servicing costs.

Bowman hydraulic oil coolers provide efficient heat transfer solutions for a wide range of hydraulic cooling requirements, ensuring they always operate at the desired temperature.



High quality

Bowman hydraulic oil coolers are high quality products incorporating the best materials and the latest technical features.

Wide range

Bowman have a comprehensive range of oil coolers including sizes for the very largest systems. Popular types are held in stock ready for immediate despatch.

Roller expanded tubes

Roller expanded tubes are available as an option, providing a highly durable joint.

Tube stack options

Cupro-nickel is the standard tube material on all units, but stainless steel or titanium are also available.

High flow versions

If the oil flow is high, relative to the required heat dissipation, a 'High Flow' version can be supplied. This will also reduce the oil pressure drop.

SAE flanges

SAE oil flange connections are provided on the shell side for GL and larger Bowman oil cooler models.



sea and deep underground



Marine & land based versions

Whether the cooling medium is sea water, fresh water, or mineral rich water, Bowman has a range of hydraulic oil coolers to suit all applications.

Fully floating tube stack

Bowman shell and tube oil coolers feature a precision engineered, fully floating tube stack, which minimises thermal stresses and provides efficient heat transfer and low pressure drop.

Advanced engineering

3D CAD models are available.

Simple to maintain

The end covers are easily removable allowing the tube stack to be withdrawn, making cleaning and routine maintenance simple and straightforward.

Fire resistant fluids

For applications where the cooler will be used with fire resistant fluids, the standard nitrile seals can be changed for either Ethylene Propylene or Viton. To specify these seals, a suffix should be added to the oil cooler type number as follows:

EP (Ethylene Propylene); or VT (Viton).

IMPORTANT: when ordering replacement seals, always change the 'NT' suffix in the 'Replacement Parts' table to the correct suffix for the seal specification required.

Selection guidance

The tables on pages 4-7 list typical examples of cooler performance at given temperatures and flow rates. This information is only intended for general guidance, graphs are available which show how heat dissipation and pressure losses vary with oil and water flow.

Alternatively, by providing the following information, we can use our own computer programme to recommend the most appropriate product:

Oil type (or its viscosity at a specified temperature)	cSt at °C
Oil flow	l/min
Required oil outlet temperature	°C
Heat to be dissipated	kW
Temperature of cooling water	°C

Land based Hydraulic Oil Coolers

Designed to provide a high quality cooling solution for hydraulic systems where fresh water is the cooling medium, they are also suitable for use with heat transfer fluids, lubricating and quenching oils.

Typical examples of oil cooler performance with;
 Oil type ISO VG 37
 Oil outlet temperature 50°C
 Oil pressure drop 100 kPa
 Water inlet temperature 25°C
 Water pressure drop 50 kPa



Type	Heat Dissipated	Maximum Oil Flow	Fresh Water Flow	Internal Oil Volume	Internal Water Volume
	kW	l/min	l/min	l (litre)	l (litre)
EC 80-1425-1	4	80	80	0.26	0.31
EC100-1425-2	9	92	80	0.49	0.44
EC120-1425-3	13	77	77	0.74	0.57
EC140-1425-4	17	68	72	0.97	0.71
EC160-1425-5	22	64	66	1.30	0.91
FC 80-1426-1	13	140	140	0.75	0.65
FC100-1426-2	19	145	135	1.10	0.84
FC120-1426-3	26	116	125	1.50	1.06
FC140-1426-4	35	105	120	2.00	1.35
FC160-1426-5	45	96	108	2.60	1.68
FG 80-1427-1	28	192	185	1.64	1.26
FG100-1427-2	37	190	175	2.40	1.56
FG120-1427-3	50	160	160	3.00	1.96
FG140-1427-4	62	160	150	3.90	2.42
FG160-1427-5	79	145	135	5.00	2.97
FG200-1427-7	123	130	120	7.58	4.55
GL140-1428-2	56	300	300	3.60	3.10
GL180-1428-3	73	285	280	4.80	3.80
GL240-1428-4	93	280	260	6.30	4.60
GL320-1428-5	114	270	240	8.00	5.50
GL400-1428-6	146	240	220	10.00	6.60
GL480-1428-7	172	235	205	12.20	7.70
GK190-1658-3	112	460	420	7.00	6.30
GK250-1658-4	144	445	385	9.00	7.50
GK320-1658-5	181	430	355	11.60	9.00
GK400-1658-6	221	420	325	14.60	10.60
GK480-1658-7	259	400	300	17.40	12.30
GK600-1658-8	329	365	275	22.10	14.70
JK190-1661-3	145	830	650	9.70	8.80
JK250-1661-4	186	740	550	12.50	10.40
JK320-1661-5	232	690	500	16.10	12.50
JK400-1661-6	283	650	460	20.30	14.70
JK480-1661-7	335	620	430	24.20	17.10
JK600-1661-8	401	600	400	30.70	20.40
PK190-1669-3	212	1600	900	13.60	16.00
PK250-1669-4	270	1240	840	17.70	18.60
PK320-1669-5	336	1060	750	22.60	21.80
PK400-1669-6	414	950	700	28.50	25.30
PK480-1669-7	497	890	650	34.00	29.00
PK600-1669-8	660	750	600	42.50	34.40
RK400-1698-6	570	1450	1180	43.40	37.90
RK600-1698-8	900	1240	850	65.20	50.10

Marine Hydraulic Oil Coolers

Marine specification hydraulic oil coolers are designed to withstand aggressive cooling media, such as sea water, or mineral rich/contaminated water.

Typical examples of oil cooler performance with,
 Oil type ISO VG 37
 Oil outlet temperature 50°C
 Oil pressure drop 100 kPa
 Water inlet temperature 25°C
 Water pressure drop 50 kPa



Type	Heat Dissipated	Maximum Oil Flow	Maximum Sea Water Flow	Internal Oil Volume	Internal Water Volume
	kW	l/min	l/min	l (litre)	l (litre)
EC 80-3875-1	4	80	50	0.26	0.31
EC100-3875-2	8	92	50	0.49	0.44
EC120-3875-3	12	77	50	0.74	0.57
EC140-3875-4	16	68	50	0.97	0.71
EC160-3875-5	20	64	50	1.30	0.91
FC 80-3876-1	12	140	80	0.75	0.65
FC100-3876-2	17	145	80	1.10	0.84
FC120-3876-3	23	116	80	1.50	1.06
FC140-3876-4	31	105	80	2.00	1.35
FC160-3876-5	40	96	80	2.60	1.68
FG 80-3877-1	25	192	110	1.64	1.26
FG100-3877-2	33	190	110	2.40	1.56
FG120-3877-3	44	160	110	3.00	1.96
FG140-3877-4	56	160	110	3.90	2.42
FG160-3877-5	72	145	110	5.00	2.97
FG200-3877-7	123	130	110	7.58	4.55
GL140-3878-2	51	300	200	3.60	3.10
GL180-3878-3	67	285	200	4.80	3.80
GL240-3878-4	86	280	200	6.30	4.60
GL320-3878-5	107	270	200	8.00	5.50
GL400-3878-6	139	240	200	10.00	6.60
GL480-3878-7	167	235	200	12.20	7.70
GK190-3879-3	102	460	300	7.00	6.30
GK250-3879-4	133	445	300	9.00	7.50
GK320-3879-5	171	430	300	11.60	9.00
GK400-3879-6	211	420	300	14.60	10.60
GK480-3879-7	256	400	300	17.40	12.30
GK600-3879-8	343	365	300	22.10	14.70
JK190-3881-3	132	830	400	9.70	8.80
JK250-3881-4	169	740	400	12.50	10.40
JK320-3881-5	211	690	400	16.10	12.50
JK400-3881-6	265	650	400	20.30	14.70
JK480-3881-7	320	620	400	24.20	17.10
JK600-3881-8	395	600	400	30.70	20.40
PK190-3880-3	196	1600	650	13.60	16.00
PK250-3880-4	252	1240	650	17.70	18.60
PK320-3880-5	319	1060	650	22.60	21.80
PK400-3880-6	399	950	650	28.50	25.30
PK480-3880-7	491	890	650	34.00	29.00
PK600-3880-8	682	750	650	42.50	34.40
RK400-5882-6	570	1450	900	43.40	37.90
RK600-5882-8	900	1240	900	65.20	50.10

Note: RK 400 & RK 600 models are only available with 'C' Coat end covers.

High temperature oil (to 150°C)

For applications where the oil is at higher temperatures, Bowman offer a range of oil coolers suitable for temperatures up to 150°C.

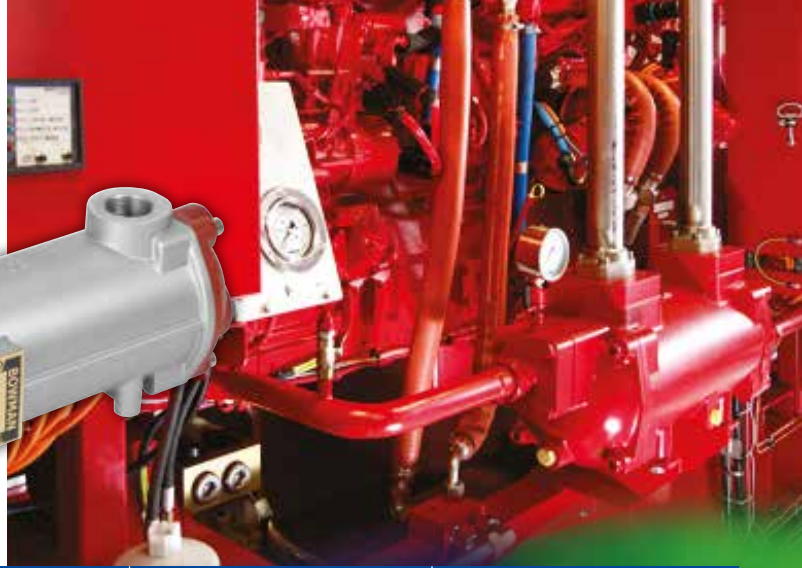

Type	Maximum Oil Flow	Fresh Water Flow	Internal Oil Volume	Internal Water Volume
	l/min	l/min	l (litre)	l (litre)
EC 80-3145-1	80	80	0.26	0.31
EC100-3145-2	92	80	0.49	0.44
EC120-3145-3	77	77	0.74	0.57
EC140-3145-4	68	72	0.97	0.71
EC160-3145-5	64	66	1.30	0.91
FC 80-3146-1	140	140	0.75	0.65
FC100-3146-2	145	135	1.10	0.84
FC120-3146-3	116	125	1.50	1.06
FC140-3146-4	105	120	2.00	1.35
FC160-3146-5	96	108	2.60	1.68
FG 80-3147-1	192	185	1.64	1.26
FG100-3147-2	190	175	2.40	1.56
FG120-3147-3	160	160	3.00	1.96
FG140-3147-4	160	150	3.90	2.42
FG160-3147-5	145	135	5.00	2.97
FG200-3147-7	130	120	7.58	4.53
GL140-3148-2	300	300	3.60	3.10
GL180-3148-3	285	280	4.80	3.80
GL240-3148-4	280	260	6.30	4.60
GL320-3148-5	270	240	8.00	5.50
GL400-3148-6	240	220	10.00	6.60
GL480-3148-7	235	205	12.20	7.70
GK190-3149-3	460	420	7.00	6.30
GK250-3149-4	445	385	9.00	7.50
GK320-3149-5	430	355	11.60	9.00
GK400-3149-6	420	325	14.60	10.60
GK480-3149-7	400	300	17.40	12.30
GK600-3149-8	365	275	22.10	14.70
JK190-3152-3	830	600	9.70	8.80
JK250-3152-4	740	550	12.50	10.40
JK320-3152-5	690	500	16.10	12.50
JK400-3152-6	650	460	20.30	14.70
JK480-3152-7	620	430	24.20	17.10
JK600-3152-8	600	400	30.70	20.40
PK190-3150-3	1600	900	13.60	16.00
PK250-3150-4	1240	840	17.70	18.60
PK320-3150-5	1060	750	22.60	21.80
PK400-3150-6	950	700	28.50	25.30
PK480-3150-7	890	650	34.00	29.00
PK600-3150-8	750	600	42.50	34.40
RK400-3155-6	1450	1180	43.40	37.90
RK600-3155-8	1240	850	65.20	50.10

Extreme temperature oil (to 200°C)

For operational conditions where extreme oil temperatures are encountered, Bowman offer a range of oil coolers designed to operate at temperatures up to 200°C. These units feature a cast iron shell, Viton seals and a specially constructed tube stack.



Type	Maximum Oil Flow	Maximum Fresh Water Flow	Internal Oil Volume	Internal Water Volume
	l/min	l/min	l (litre)	l (litre)
EC120-3635-3	77	77	0.49	0.44
FC100-3636-2	145	135	1.10	0.84
FG100-3637-2	190	175	2.40	1.56
FG120-3637-3	160	160	3.00	1.96
FG140-3637-4	160	150	3.90	2.42
FG160-3637-5	145	135	5.00	2.97
GL140-3638-2	300	300	3.60	3.10
GL240-3638-4	285	280	6.30	4.60

Mining Hydraulic Oil Coolers

For underground mining applications, a special range of oil coolers is available suitable for use with water pressures up to 35 bar. These units have a cast iron shell, strengthened end covers, Viton seals and a special tube stack.

Typical examples of oil cooler performance with,
 Oil type ISO VG 37
 Oil outlet temperature 50°C
 Oil pressure drop 100 kPa
 Water inlet temperature 25°C
 Water pressure drop 50 kPa



Type	Heat Dissipated	Maximum Oil Flow	Maximum Fresh Water Flow	Internal Oil Volume	Internal Water Volume
	kW	l/min	l/min	l (litre)	l (litre)
EC120-3425-3	13	77	77	0.49	0.44
FC100-3426-2	19	145	135	1.10	0.94
FG100-3427-2	37	190	175	2.40	1.56
FG120-3427-3	50	160	160	3.00	1.96
FG140-3427-4	62	160	150	3.90	2.42
FG160-3427-5	79	145	135	5.00	2.97
GL140-3428-2	56	300	300	3.60	3.10
GL240-3428-4	93	280	260	6.30	4.60

EC Range

Three pass version

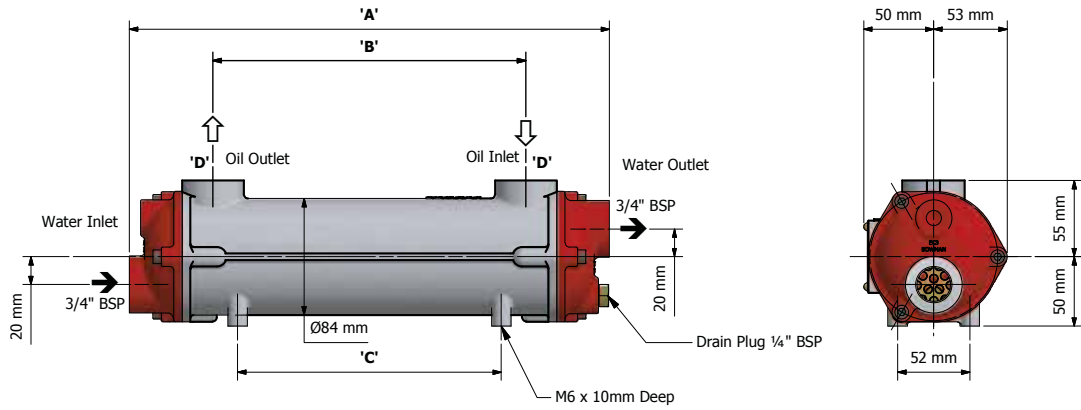

Screw Tightening Torque 8 Nm

Type	Weight	A	B	C	D
	kg	mm	mm	mm	BSP
EC 80	2.4	174	60	60	1/2"
EC100	3.2	260	140	104	3/4"
EC120	3.8	346	226	190	3/4"
EC140	4.8	444	324	288	3/4"
EC160	5.7	572	452	416	3/4"

FC Range

Three pass version

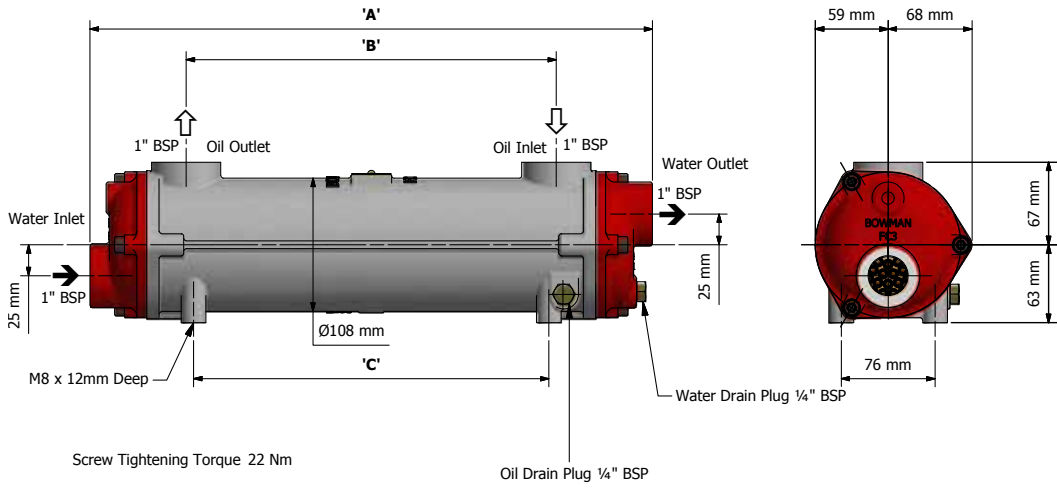

Screw Tightening Torque 22 Nm

Oil Drain Plug 1/4" BSP

Type	Weight	A	B	C
	kg	mm	mm	mm
FC 80	5.5	272	116	104
FC100	6.3	358	202	190
FC120	7.3	456	300	288
FC140	9.4	584	428	288
FC160	11.0	730	574	434

Maximum working oil pressure 20 bar.
Maximum working water pressure 16 bar.

Maximum working oil temperature 120°C.
Maximum working water temperature 110°C.

FG Range

Three pass version

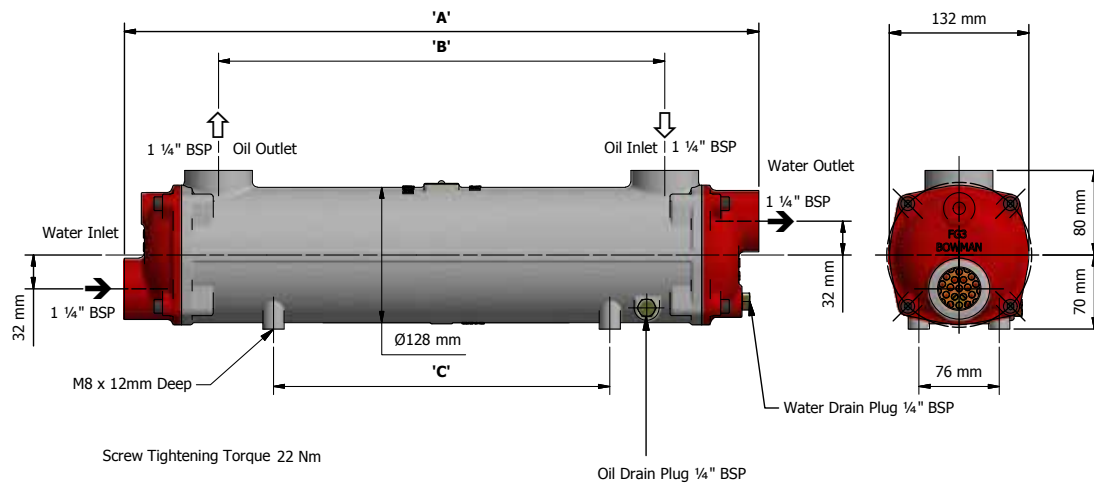

Type	Weight kg	A mm	B mm	C mm
FG 80	8.5	374	196	92
FG100	10.0	472	294	190
FG120	12.0	600	422	318
FG140	14.5	746	568	464
FG160	17.5	924	746	642
FG200	24.0	1330	1152	1048

GL Range

Three pass version

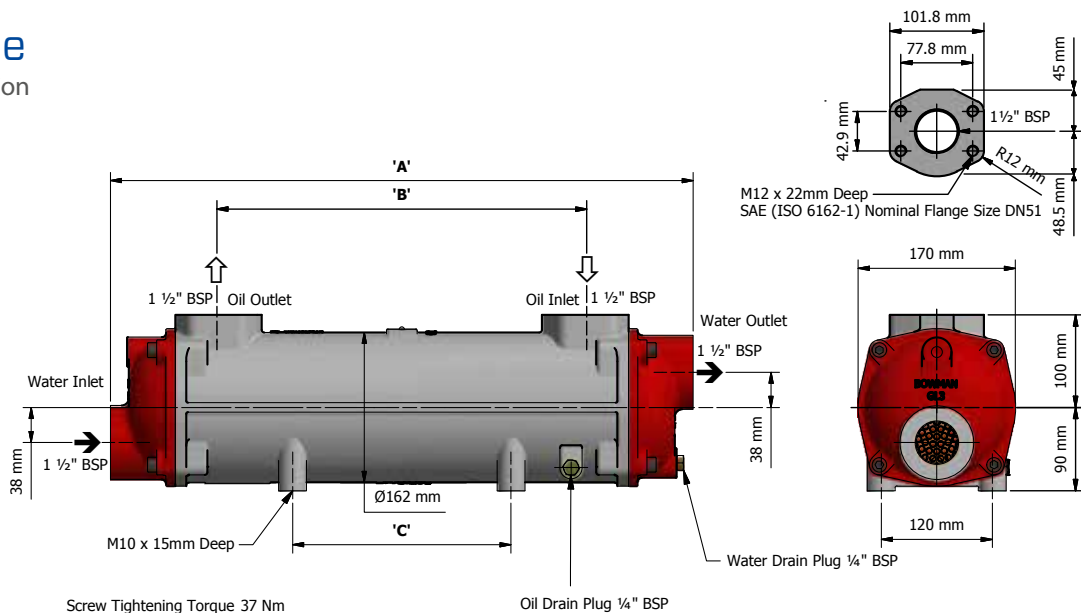

Type	Weight kg	A mm	B mm	C mm
GL140	18	502	272	108
GL180	21	630	400	236
GL240	25	776	546	382
GL320	30	954	724	560
GL400	36	1156	926	762
GL480	42	1360	1130	966

Maximum working oil pressure 20 bar.
Maximum working water pressure 16 bar.

Maximum working oil temperature
Maximum working water temperature

120°C.
110°C.

GK Range

Three pass version

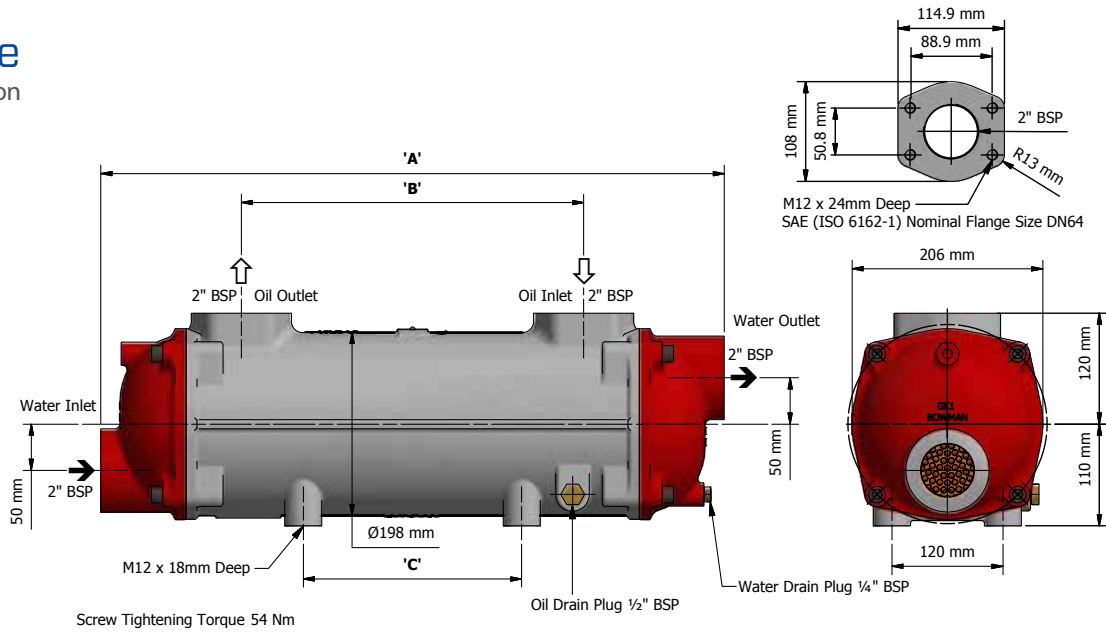

Type	Weight kg	A mm	B mm	C mm
GK190	34	674	370	236
GK250	39	820	516	382
GK320	46	998	694	560
GK400	54	1200	896	762
GK480	62	1404	1100	966
GK600	74	1708	1404	1270

JK Range

Three pass version

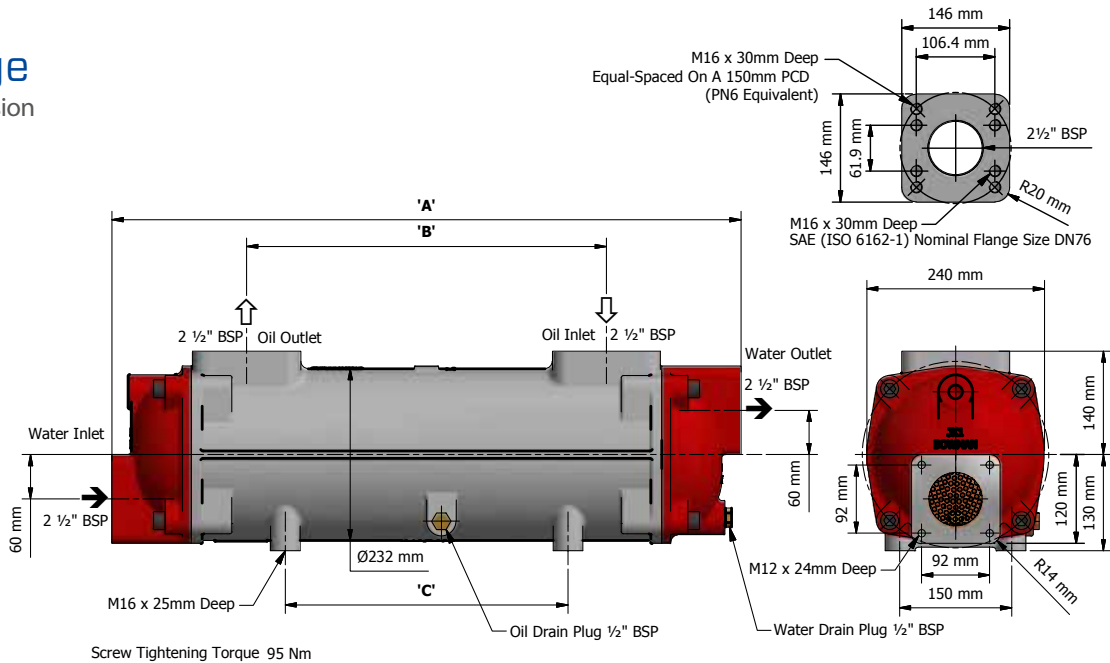

Type	Weight kg	A mm	B mm	C mm
JK190	58	704	340	236
JK250	66	850	486	382
JK320	78	1028	664	560
JK400	92	1230	866	762
JK480	105	1434	1070	966
JK600	126	1738	1374	1270

Maximum working oil pressure 20 bar.
Maximum working water pressure 16 bar.

Maximum working oil temperature
Maximum working water temperature

120°C.
110°C.

PK Range

Three pass version

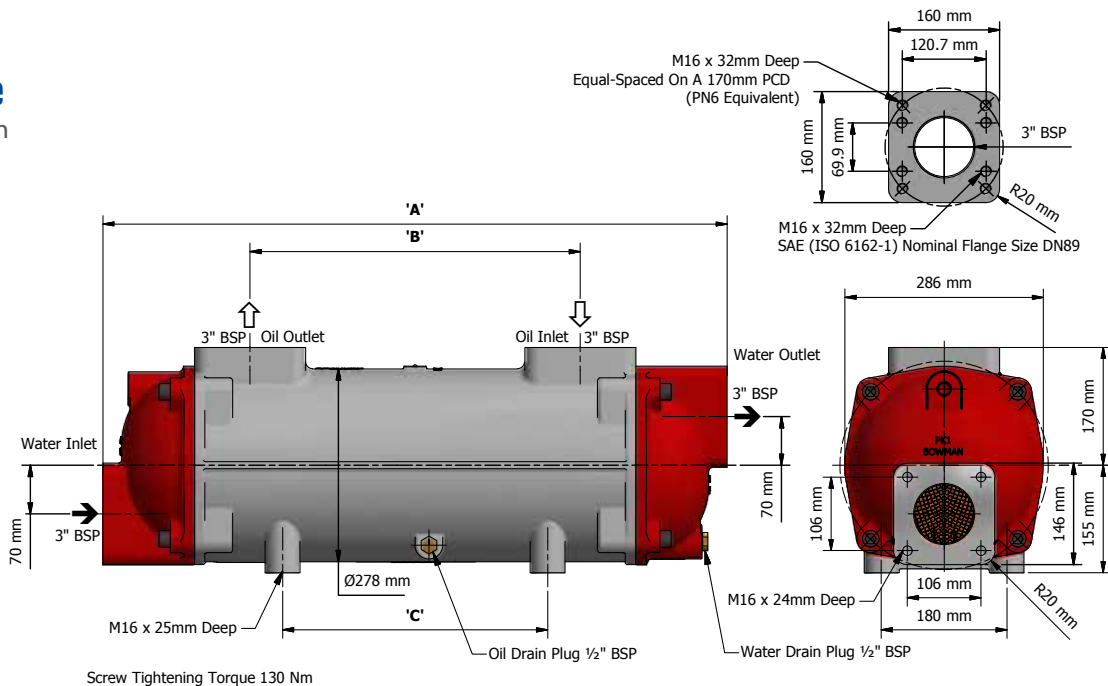

Type	Weight	A	A*	B	C
	kg	mm	mm	mm	mm
PK190	81	754	706	330	236
PK250	94	900	852	476	382
PK320	110	1078	1030	654	560
PK400	125	1280	1232	856	762
PK480	140	1484	1436	1060	966
PK600	158	1788	1740	1364	1270

Please note: dimensions marked A* are for marine versions only.

RK Range

Three pass version

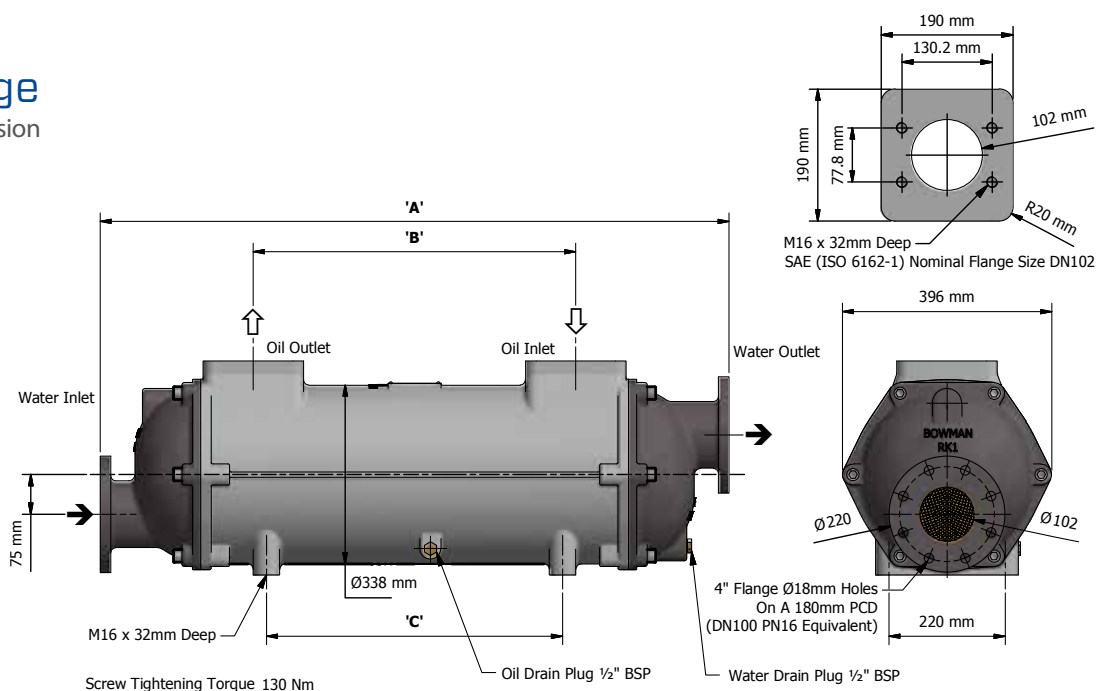

Type	Weight	A	B	C
	kg	mm	mm	mm
RK400	186	1392	812	762
RK600	246	1900	1320	1270

Maximum working oil pressure 20 bar.
Maximum working water pressure 16 bar.

Maximum working oil temperature 120°C.
Maximum working water temperature 110°C.

Three, Two and Single Pass Oil Coolers

There is the choice of three, two or single pass flow to suit operating conditions.

Three pass

This is our preferred and standard arrangement. Three pass units transfer more heat from a given water flow, splitting the internal area of the tube stack into three separate passes. Cooling water enters via the lower connection and passes through the first third of the tubes. It is then re-directed in a second pass, which returns the water back through the middle section, before the final third pass, leaving from the upper connection.

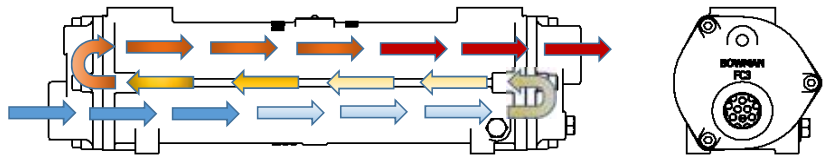

Two pass*

Ideal for applications where space is limited, two pass units have specially designed end covers which separate the internal area of the tube stack into two separate passes. Cooling water enters and leaves from connections on the same end cover, simplifying pipework. Two pass units can also accommodate higher flow rates than three pass units.

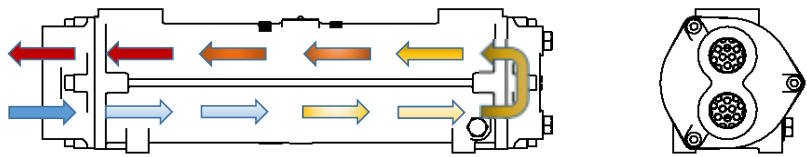

Single pass*

These units are only chosen when the cooling water flow rate is unavoidably high. The water passes through all of the tubes in a single pass.

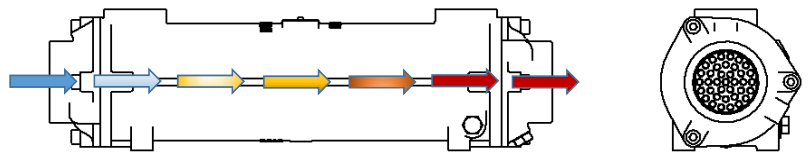

*These units are available at extra cost and with slightly longer delivery lead times. Please contact our sales team for details.

Double Seal Retaining Flange

Rising levels of waste material in the ocean are dictating that regular cleaning and maintenance are now important to ensure oil coolers operate at their peak efficiency.

However, cleaning hydraulic oil coolers on board ship can be time-consuming and potentially hazardous, as even when drained, the unit may still contain some fluid, which can spill onto the deck when the tube stack is removed.

To minimise down time and eliminate deck spillage hazards, Bowman has developed the Double Seal Retaining Flange (DSRF) for marine hydraulic cooling applications.

Available for the GL and larger size models, the DSRF fits between the end cover and the heat exchanger body, enabling the cooling water side of the unit to be cleaned and inspected - without having to disturb the oil side.

For full product specification details, please contact our technical sales team



Titanium Tube Stacks

Titanium is the ultimate 'fit and forget' solution for any application where very aggressive water conditions exist, such as salt water, or contaminated/mineral rich fresh water. Titanium resists chemical attack and also effectively eliminates the risk of premature failure of the tube stack due to galvanic corrosion.

Titanium tube stacks are now available as an option for Bowman hydraulic oil coolers, providing a durable, long life solution for the most demanding operating conditions. All Bowman Titanium tube stacks have a 10 year guarantee on all Titanium material in contact with the cooling water and, as a further advantage, they can also operate at higher flow rates compared to standard cupro-nickel, without the risk of tube erosion.

GUARANTEED
10
YEARS

Full 10 year guarantee on all titanium material in contact with cooling water.



Shipboard Installation of Marine Hydraulic Oil Coolers

Product Mounting

The oil cooler can be mounted either horizontally or vertically as illustrated.

Counter Flow Installation

The oil cooler must always be installed in counter flow – i.e. where the sea water flows in the opposite direction to the oil, as illustrated.

Maximum Sea Water Flow Rates

The maximum permitted sea water flow rates for Bowman oil coolers are as follows:

EC range	50 l/min.	JK range	400 l/min.
FC range	80 l/min.	PK range	650 l/min.
FG range	110 l/min.	RK range	900 l/min.
GL range	200 l/min.		
GK range	300 l/min.		

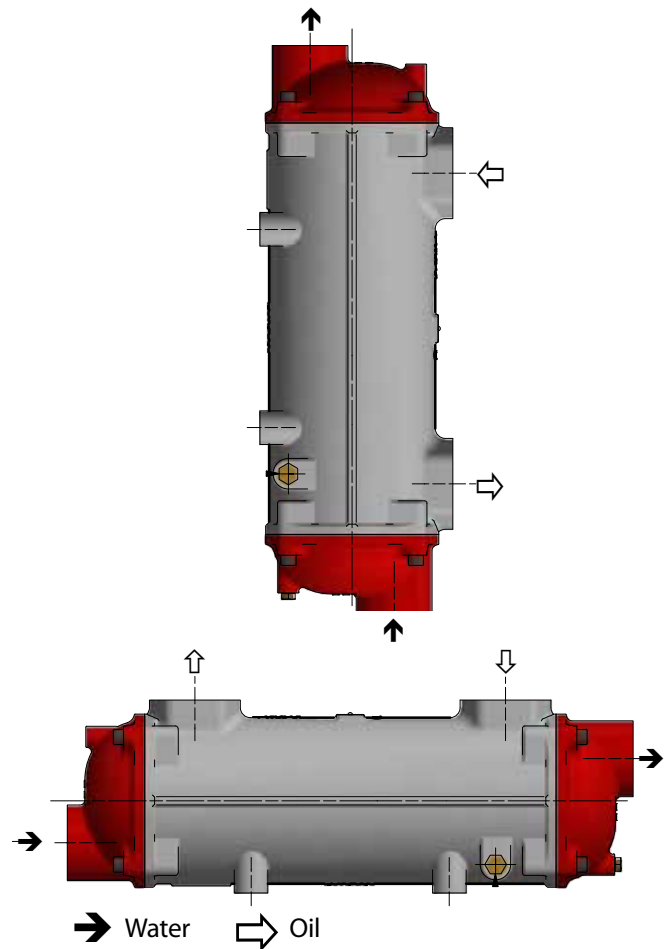

Orifice Plates

If the sea water supply is taken from a ship's main, it is important to ensure that the recommended flow rate cannot be exceeded.

This will normally mean that an orifice plate must be fitted in the pipework at least 1m before the oil cooler, with the orifice size calculated to ensure that the maximum sea water flow rate cannot be exceeded.

The correct orifice diameter can be determined from the table below.

If this precaution is not taken, it is possible that the sea water flow through the cooler may be many times the recommended maximum, leading to rapid failure.

Recommended Orifice Plate Sizes

Oil Cooler Series	Max. sea water flow l/min	Orifice diameter in mm for max. sea water flow								
		2 bar	3 bar	4 bar	5 bar	6 bar	7 bar	8 bar	9 bar	10 bar
EC	50	9.5	8.5	8.0	7.5	7.2	6.8	6.7	6.5	6.3
FC	80	12	11	10	9.5	9.0	8.7	8.4	8.2	8.0
FG	110	14	13	12	11	10	10	9.8	9.6	9.3
GL	200	19	17	16	15	14	14	13	13	13
GK	300	23	21	19	18	17	17	16	16	15
JK	400	27	24	22	21	20	20	19	18	18
PK	650	34	31	28	27	26	25	24	23	23
RK	900	40	36	34	32	30	29	28	27	26

General Guidelines for Operation and Maintenance of Oil Coolers

Bowman oil coolers are renowned for combining excellent heat transfer, with long life. To ensure the unit continues to operate at its peak performance and to minimise the possibility of damage or premature failure, we suggest the following good practice:

- 1: For hydraulic applications, the oil cooler should be in the return pipe to tank as shown in the diagram. If the flow is subject to violent fluctuations in flow and pressure, it may be advisable to connect the cooler in a separate circuit with its own pump.
- 2: Oil coolers should be mounted as shown opposite to ensure that they operate full of water and should be connected for counter flow.

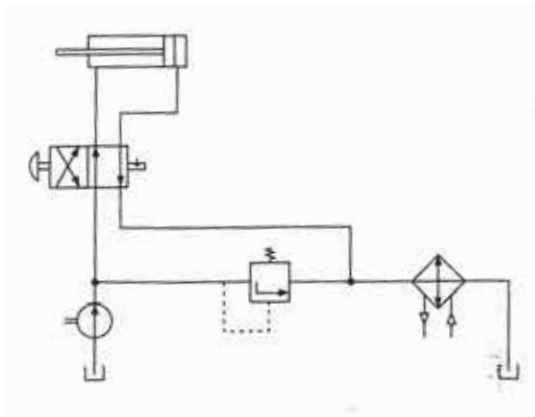

- 3: The water outlet pipe from the oil cooler should always have an uninterrupted run back to the waste or return water circuit.
- 4: Ensure that the stated maximum water flow rate is not exceeded and that the pH is between 7.2 and 7.8.
- 5: If a water flow control valve is used, it should be of the modulating type and fitted on the inlet side, so that the cooler is not pressurised when the system is shut down.
- 6: If the hydraulic system is not being used, isolate the oil cooler from the water pressure.
- 7: Stainless steel water pipes and fittings should not be used adjacent to the oil cooler.
- 8: **Important note for marine applications:** during commissioning, shutdown and standby periods, if the oil cooler has not been used over a 4-6 day period, it should be drained, cleaned and kept dry. Where this procedure is not possible, drain the stagnant water and refill the oil cooler with clean sea or fresh water, which should be replaced with oxygenated sea water every 2-3 days to avoid further decomposition.

Before installing the oil cooler, always read the 'Installation, Operation & Maintenance Guide' which can be downloaded from our web site

Special Cooling Requirements

Bowman offer one of the widest ranges of hydraulic oil coolers available, most applications can be covered from our standard range.

However, if you have a special application that is not listed in this brochure, please contact our sales team, who can advise on the most appropriate product from our range.

For some applications where a single unit may be too small for the required oil flow, multiple units can be connected in parallel. We can also advise on installation, particularly for unusual or safety critical applications.

Servicing the Unit

By simply removing the end cover retaining screws, the tube stack can be removed from the body for routine cleaning and maintenance. On reassembly, it is recommended that the "O" seals are replaced to ensure a reliable joint. A comprehensive range of replacement parts is available for all Bowman hydraulic oil coolers, these are listed on pages 16, 17, 18 & 19.

NOTE: when ordering replacement parts, always quote the part number, which is given on the nameplate.



Land based Hydraulic Oil Cooler Replacement Parts

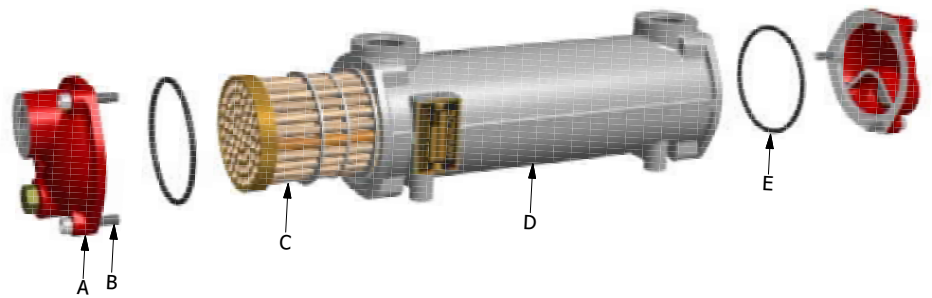

Type	End Covers (A)	Screws (B)	Tube stack (C)	Body (D)	"O" Seals (E)
EC 80-1425-1			785-1TN1A	EC21-978AL	
EC100-1425-2			785-2TN1A	EC10-783-2AL	
EC120-1425-3	EC3-1040CI	HS06X30DP	785-3TN1A	EC12-783-3AL	AN12NT
EC140-1425-4			785-4TN1A	EC14-783-4AL	
EC160-1425-5			785-5TN1A	EC16-783-5AL	
FC 80-1426-1			1530-1TN1A	FC 8-1200-1AL	
FC100-1426-2			1530-2TN1A	FC10-1200-2AL	
FC120-1426-3	FC3-1281CI	HS08X35DP	1530-3TN1A	FC12-1200-3AL	OS46NT
FC140-1426-4			1530-4TN1A	FC14-1200-4AL	
FC160-1426-5			1530-5TN1A	FC16-1200-5AL	
FG 80-1427-1			1959-1TN1A	FG 8-1650-1AL	
FG100-1427-2			1959-2TN1A	FG10-1650-2AL	
FG120-1427-3			1959-3TN1A	FG12-1650-3AL	
FG140-1427-4	FG3-1583CI	HS08X35DP	1959-4TN1A	FG14-1650-4AL	OS52NT
FG160-1427-5			1959-5TN1A	FG16-1650-5AL	
FG200-1427-7			1959-7TN1A	FG20-1650-7AL	
GL140-1428-2			1798-2TN1A	GL15-3136NF-2AL6	
GL180-1428-3			1798-3TN1A	GL19-3136NF-3AL6	
GL240-1428-4			1798-4TN1A	GL25-3136NF-4AL6	
GL320-1428-5	GL3-3141CI	HS10X40DP	1798-5TN1A	GL33-3136NF-5AL6	OS63NT
GL400-1428-6			1798-6TN1A	GL41-3136NF-6AL6	
GL480-1428-7			1798-7TN1A	GL49-3136NF-7AL6	
GK190-1658-3			2315-3TN1A	GK19-2865NF-3AL7	
GK250-1658-4			2315-4TN1A	GK25-2865NF-4AL7	
GK320-1658-5			2315-5TN1A	GK32-2865NF-5AL7	
GK400-1658-6	GK1-2864CI	HS12X50DP	2315-6TN1A	GK40-2865NF-6AL7	OS69NT
GK480-1658-7			2315-7TN1A	GK48-2865NF-7AL7	
GK600-1658-8			2315-8TN1A	GK60-2865NF-8AL7	
JK190-1661-3			3334-3TN1A	JK19-3332NF-3AL8	
JK250-1661-4			3334-4TN1A	JK25-3332NF-4AL8	
JK320-1661-5			3334-5TN1A	JK32-3332NF-5AL8	
JK400-1661-6	JK1-3333CI	HS16X70DP	3334-6TN1A	JK40-3332NF-6AL8	OS74NT
JK480-1661-7			3334-7TN1A	JK48-3332NF-7AL8	
JK600-1661-8			3334-8TN1A	JK60-3332NF-8AL8	
PK190-1669-3			2829-3TN1A	PK19-2919NF-3AL9	
PK250-1669-4			2829-4TN1A	PK25-2919NF-4AL9	
PK320-1669-5			2829-5TN1A	PK32-2919NF-5AL9	
PK400-1669-6	PK1-2918CI	HS16X70DP	2829-6TN1A	PK40-2919NF-6AL9	OS81NT
PK480-1669-7			2829-7TN1A	PK48-2919NF-7AL9	
PK600-1669-8			2829-8TN1A	PK60-2919NF-8AL9	
RK400-1698-6	RK1-5451CIC	HS16X70DP	5455-6TN1A	RK40-5450NF-6AL0	OS453NT
RK600-1698-8	RK1-5451CIC	HS16X70DP	5455-8TN1A	RK60-5450NF-8AL0	OS453NT

NOTE: when ordering replacement parts, always quote the part number, which is given on the nameplate.

Marine Hydraulic Oil Cooler Replacement Parts

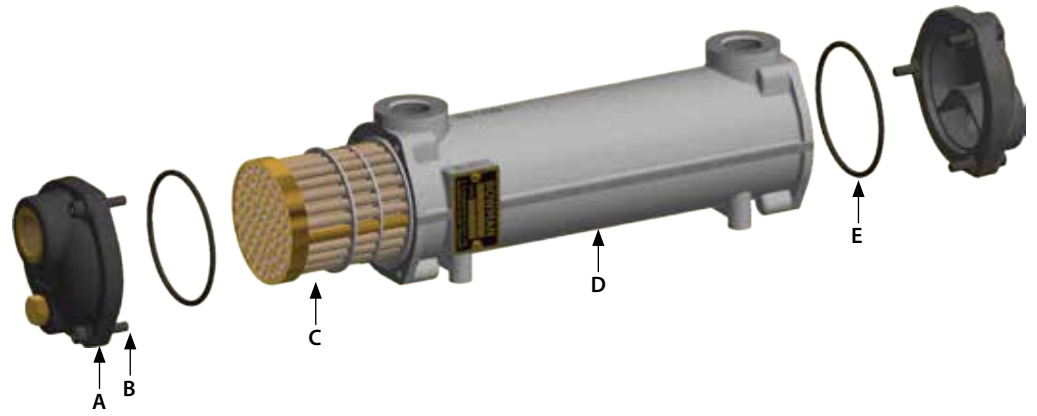

Type	End Covers (A)	Screws (B)	Tube stack (C)	Body (D)	"O" Seals (E)
EC 80-3875-1			785-1TN1A	EC21-978AL	
EC100-3875-2			785-2TN1A	EC10-783-2AL	
EC120-3875-3	EC3C-5480	HS06X30DP	785-3TN1A	EC12-783-3AL	AN12NT
EC140-3875-4			785-4TN1A	EC14-783-4AL	
EC160-3875-5			785-5TN1A	EC16-783-5AL	
FC 80-3876-1			1530-1TN1A	FC 8-1200-1AL	
FC100-3876-2			1530-2TN1A	FC10-1200-2AL	
FC120-3876-3	FC3C-5481	HS08X35DP	1530-3TN1A	FC12-1200-3AL	OS46NT
FC140-3876-4			1530-4TN1A	FC14-1200-4AL	
FC160-3876-5			1530-5TN1A	FC16-1200-5AL	
FG 80-3877-1			1959-1TN1A	FG 8-1650-1AL	
FG100-3877-2			1959-2TN1A	FG10-1650-2AL	
FG120-3877-3	FG3C-5482	HS08X35DP	1959-3TN1A	FG12-1650-3AL	OS52NT
FG140-3877-4			1959-4TN1A	FG14-1650-4AL	
FG160-3877-5			1959-5TN1A	FG16-1650-5AL	
FG200-3877-7			1959-7TN1A	FG20-1650-7AL	
GL140-3878-2			1798-2TN1A	GL15-3136NF-2AL6	
GL180-3878-3			1798-3TN1A	GL19-3136NF-3AL6	
GL240-3878-4			1798-4TN1A	GL25-3136NF-4AL6	
GL320-3878-5	GL3C-5483	HS10X40DP	1798-5TN1A	GL33-3136NF-5AL6	OS63NT
GL400-3878-6			1798-6TN1A	GL41-3136NF-6AL6	
GL480-3878-7			1798-7TN1A	GL49-3136NF-7AL6	
GK190-3879-3			2315-3TN1A	GK19-2865NF-3AL7	
GK250-3879-4			2315-4TN1A	GK25-2865NF-4AL7	
GK320-3879-5			2315-5TN1A	GK32-2865NF-5AL7	
GK400-3879-6	GK1-2864BR	HS12X50DP	2315-6TN1A	GK40-2865NF-6AL7	OS69NT
GK480-3879-7			2315-7TN1A	GK48-2865NF-7AL7	
GK600-3879-8			2315-8TN1A	GK60-2865NF-8AL7	
JK190-3881-3			3334-3TN1A	JK19-3332NF-3AL8	
JK250-3881-4			3334-4TN1A	JK25-3332NF-4AL8	
JK320-3881-5			3334-5TN1A	JK32-3332NF-5AL8	
JK400-3881-6	JK1-4353BR	HS16X70DP	3334-6TN1A	JK40-3332NF-6AL8	OS74NT
JK480-3881-7			3334-7TN1A	JK48-3332NF-7AL8	
JK600-3881-8			3334-8TN1A	JK60-3332NF-8AL8	
PK190-3880-3			2829-3TN1A	PK19-2919NF-3AL9	
PK250-3880-4			2829-4TN1A	PK25-2919NF-4AL9	
PK320-3880-5			2829-5TN1A	PK32-2919NF-5AL9	
PK400-3880-6	PK1-4352BR	HS16X70DP	2829-6TN1A	PK40-2919NF-6AL9	OS81NT
PK480-3880-7			2829-7TN1A	PK48-2919NF-7AL9	
PK600-3880-8			2829-8TN1A	PK60-2919NF-8AL9	
RK400-5882-6	RK1-5451CIC	HS16X70DP	5455-6TN1A	RK40-5450NF-6AL0	OS453NT
RK600-5882-8	RK1-5451CIC	HS16X70DP	5455-8TN1A	RK60-5450NF-8AL0	OS453NT

NOTE: when ordering replacement parts, always quote the part number, which is given on the nameplate.

BOWMAN®

High Temperature Oil (to 150°C) Replacement Parts

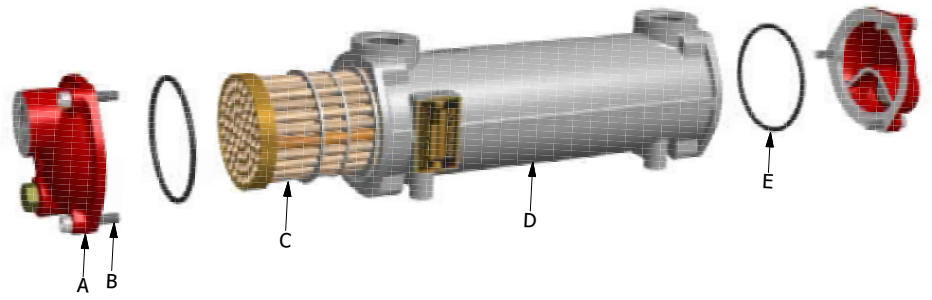

Type	End Covers (A)	Screws (B)	Tube stack (C)	Body (D)	"O" Seals (E)
EC 80-3145-1			785-1TN2A	EC21-978AL	
EC100-3145-2			785-2TN2A	EC10-783-2AL	
EC120-3145-3	EC3-1040CI	HS06X30DP	785-3TN2A	EC12-783-3AL	AN12VT
EC140-3145-4			785-4TN2A	EC14-783-4AL	
EC160-3145-5			785-5TN2A	EC16-783-5AL	
FC 80-3146-1			1530-1TN2A	FC 8-1200-1AL	
FC100-3146-2			1530-2TN2A	FC10-1200-2AL	
FC120-3146-3	FC3-1281CI	HS08X35DP	1530-3TN2A	FC12-1200-3AL	OS46VT
FC140-3146-4			1530-4TN2A	FC14-1200-4AL	
FC160-3146-5			1530-5TN2A	FC16-1200-5AL	
FG 80-3147-1			1959-1TN2A	FG 8-1650-1AL	
FG100-3147-2			1959-2TN2A	FG10-1650-2AL	
FG120-3147-3			1959-3TN2A	FG12-1650-3AL	
FG140-3147-4	FG3-1583CI	HS08X35DP	1959-4TN2A	FG14-1650-4AL	OS52VT
FG160-3147-5			1959-5TN2A	FG16-1650-5AL	
GL140-3148-2			1798-2TN2A	GL15-3136NF-2AL6	
GL180-3148-3			1798-3TN2A	GL19-3136NF-3AL6	
GL240-3148-4			1798-4TN2A	GL25-3136NF-4AL6	
GL320-3148-5	GL3-3141CI	HS10X40DP	1798-5TN2A	GL33-3136NF-5AL6	OS63VT
GL400-3148-6			1798-6TN2A	GL41-3136NF-6AL6	
GL480-3148-7			1798-7TN2A	GL49-3136NF-7AL6	
GK190-3149-3			2315-3TN2A	GK19-2865NF-3AL7	
GK250-3149-4			2315-4TN2A	GK25-2865NF-4AL7	
GK320-3149-5			2315-5TN2A	GK32-2865NF-5AL7	
GK400-3149-6	GK1-2864CI	HS12X50DP	2315-6TN2A	GK40-2865NF-6AL7	OS69VT
GK480-3149-7			2315-7TN2A	GK48-2865NF-7AL7	
GK600-3149-8			2315-8TN2A	GK60-2865NF-8AL7	
JK190-3152-3			3334-3TN2A	JK19-3332NF-3AL8	
JK250-3152-4			3334-4TN2A	JK25-3332NF-4AL8	
JK320-3152-5			3334-5TN2A	JK32-3332NF-5AL8	
JK400-3152-6	JK1-3333CI	HS16X70DP	3334-6TN2A	JK40-3332NF-6AL8	OS74VT
JK480-3152-7			3334-7TN2A	JK48-3332NF-7AL8	
JK600-3152-8			3334-8TN2A	JK60-3332NF-8AL8	
PK190-3150-3			2829-3TN2A	PK19-2919NF-3AL9	
PK250-3150-4			2829-4TN2A	PK25-2919NF-4AL9	
PK320-3150-5			2829-5TN2A	PK32-2919NF-5AL9	
PK400-3150-6	PK1-2918CI	HS16X70DP	2829-6TN2A	PK40-2919NF-6AL9	OS81VT
PK480-3150-7			2829-7TN2A	PK48-2919NF-7AL9	
PK600-3150-8			2829-8TN2A	PK60-2919NF-8AL9	
RK400-3153-6	RK1-5451CIC	HS16X70DP	5455-6TN2A	RK40-5450NF-6AL0	OS453VT
RK600-3153-8	RK1-5451CIC	HS16X70DP	5455-8TN2A	RK60-5450NF-8AL0	OS453VT

NOTE: when ordering replacement parts, always quote the part number, which is given on the nameplate.

BOWMAN®

Extreme Temperature Oil (to 200°C) Replacement Parts

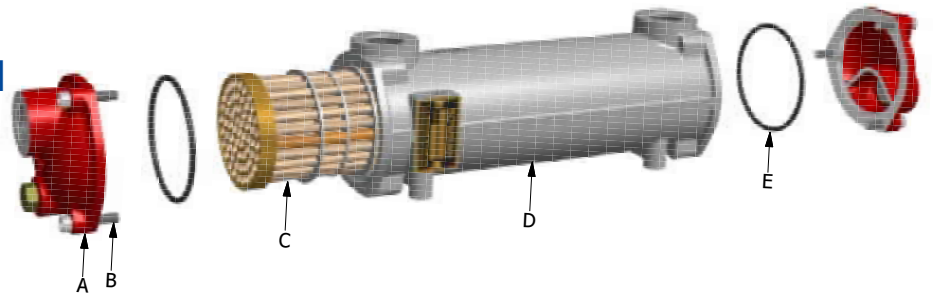

Type	End Covers (A)	Screws (B)	Tube stack (C)	Body (D)	“O” Seals (E)
EC120-3635-3	EC3-1040CI	HS06X30DP	785-3TN3B	EC71-4658-3CI	AN12VT
FC100-3636-2	FC3-1281CI	HS08X35DP	1530-2TN3B	FC70-4668-2CI	OS46VT
FG100-3637-2	FG3-1583CI	HS08X35DP	1959-2TN3B	FG10-1650-2CI	OS52VT
FG120-3637-3	FG3-1583CI	HS08X35DP	1959-3TN3B	FG12-1650-3CI	OS52VT
FG140-3637-4	FG3-1583CI	HS08X35DP	1959-4TN3B	FG14-1650-4CI	OS52VT
FG160-3637-5	FG3-1583CI	HS08X35DP	1959-5TN3B	FG16-1650-5CI	OS52VT
GL140-3638-2	GL3-3141CI	HS10X40DP	1798-2TN3B	GL15-3136-2CI	OS63VT
GL240-3638-4	GL3-3141CI	HS10X40DP	1798-4TN3B	GL25-3136-4CI	OS63VT

Mining Hydraulic Oil Cooler Replacement Parts

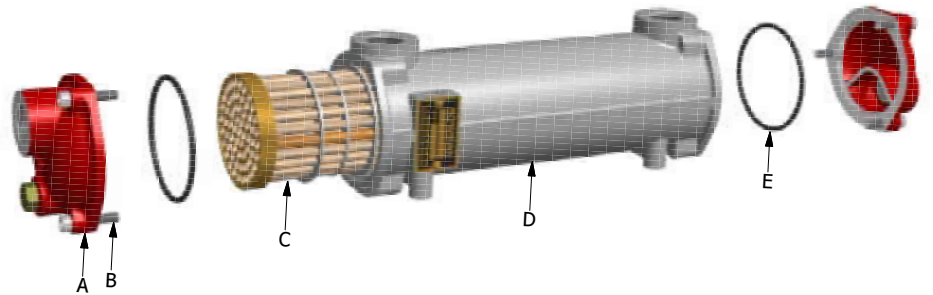

Type	End Covers (A)	Screws (B)	Tube stack (C)	Body (D)	“O” Seals (E)
EC120-3425-3	EC23-4033CI	HS06X30DP	785-3TN2B	EC71-4568-3CI	AN12VT
FC100-3426-2	FC23-4034CI	HS08X35DP	1530-2TN2B	FC70-4668-2CI	OS46VT
FG100-3427-2	FG23-4035CI	HS08X35DP	1959-2TN2B	FG10-1650-2CI	OS52VT
FG120-3427-3	FG23-4035CI	HS08X35DP	1959-3TN2B	FG12-1650-3CI	OS52VT
FG140-3427-4	FG23-4035CI	HS08X35DP	1959-4TN2B	FG14-1650-4CI	OS52VT
FG160-3427-5	FG23-4035CI	HS08X35DP	1959-5TN2B	FG16-1650-5CI	OS52VT
GL140-3428-2	GL23-4036CI	HS10A40DP	1798-2TN2B	GL15-3136NF-2CI6	OS63VT
GL240-3428-4	GL23-4036CI	HS10A40DP	1798-3TN2B	GL25-3136NF-4CI6	OS63VT

NOTE: when ordering replacement parts, always quote the part number, which is given on the nameplate.

A world of applications

Bowman has been synonymous with hydraulic system cooling for over 50 years. Renowned for providing highly efficient, reliable heat transfer solutions, Bowman oil coolers can be found in an extremely wide range of applications, for marine and offshore industries, land based machines and equipment as well as deep underground mining equipment.



Industrial Machines & Equipment

Wherever hydraulic systems require fluid cooling, Bowman oil coolers can be found at the heart of the system, protecting equipment from excessive heat loads in applications as diverse as hydraulic presses, processing machinery, active fire protection systems, materials handling equipment and plastic injection moulding machines.



Deep Underground Mining

For deep mine operations, Bowman hydraulic oil coolers are the first choice for some of the world's leading machinery and equipment manufacturers, due to their efficient heat transfer and durability. Additionally, the choice of tube stack materials and construction enables the units to operate with all types of mine water conditions, including high salt content.



Marine Deck Machinery

Designed to combine extended service life with minimal running costs, this hydraulic propulsion system replaces conventional marine gearboxes to provide smooth, quiet operation for inland commercial charter boats. Extensively proven over 1,000s of hours, Bowman's oil cooling technology is at the heart of the system.

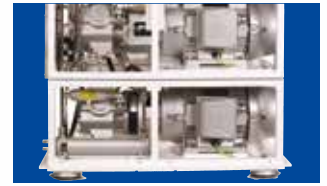

Marine Stabiliser and Thruster Systems

A pioneer in the development of advanced marine stabiliser technology and vessel roll reduction solutions, this leading USA manufacturer uses Bowman oil coolers in their hydraulic power packs to ensure the fluid power required to articulate the stabiliser fins is always kept at the optimum temperature.



All Bowman hydraulic oil coolers are produced to the highest quality in our UK manufacturing centre to ISO 9001:2008 standards. With tens of thousands of units operating reliably and efficiently around the world, you can have complete confidence when you specify Bowman hydraulic oil coolers for your project.

BOWMAN®

100 YEARS OF HEAT TRANSFER TECHNOLOGY

mdt

authorised regional warehouse & distributor of E.J. Bowman (U.K.)

info@mdtco.com

www.mdtco.com



EJ Bowman (Birmingham) Ltd, reserve the right to change specifications without prior notice.